

AIROC™ Bluetooth® Low Energy (LE) System-on-chip

Single-chip

The AIROC™ CYW20736 Bluetooth® LE SoC is a Bluetooth® 5.4 core spec compliant device that supports wireless charging profile. The CYW20736 is designed to support the entire spectrum of Bluetooth® Low Energy use cases for the medical, home automation, accessory, sensor, Internet Of Things, and wearable market segments.

CYW20736 radio has been designed to provide low power, low cost, and robust communications for applications operating in the globally available 2.4 GHz unlicensed Industrial, Scientific, and Medical (ISM) band.

The single-chip Bluetooth® low energy SoC is a monolithic component implemented in a standard digital CMOS process and requires minimal external components to make a fully compliant Bluetooth® device. CYW20736 is available in a 32-pin, 5 mm × 5 mm 32-QFN package as well as WLCSP. The CYW20736 device is supported in WICED SDK 2.x

Features

• Application Processor Features

- Arm® Cortex®-R4 32-bit RISC processor.

• Features

The following profiles are supported^[1] in ROM:

- Battery status
- Blood pressure monitor
- Find me
- Heart rate monitor
- Proximity
- Thermometer
- Weight scale
- Time

Additional profiles that can be supported^[1] from RAM include:

- Blood glucose monitor
- Temperature alarm
- Location

• Applications

- AirFuel wireless charging
- Complies with Bluetooth® core specification v5.4
- Infrared modulator
- IR learning
- Supports Adaptive Frequency Hopping
- Excellent receiver sensitivity
- 10-bit auxiliary ADC with nine analog channels
- On-chip support for serial peripheral interface (master and slave modes)
- Broadcom Serial Communications interface (compatible with NXP I²C slaves)
- Programmable output power control
- Integrated Arm® Cortex®-M3 based microprocessor core
- Automation Profile

Note

1. Full qualification and use of these profiles may require FW updates from Infineon. Some of these profiles are under development/approval at the Infineon SIG and conformity with the final approved version is pending. Contact your supplier for updates and the latest list of profiles.

Features

- Support for secure OTA
- On-chip power-on reset (POR)
- Support for EEPROM and serial flash interfaces
- Integrated low-dropout regulator (LDO)
- On-chip software controlled power management unit
- Package type:
 - 32-pin 32-QFN package (5 mm × 5 mm)
 - 80-pin WLCSP package (2104 μm × 2085 μm)
- RoHS compliant

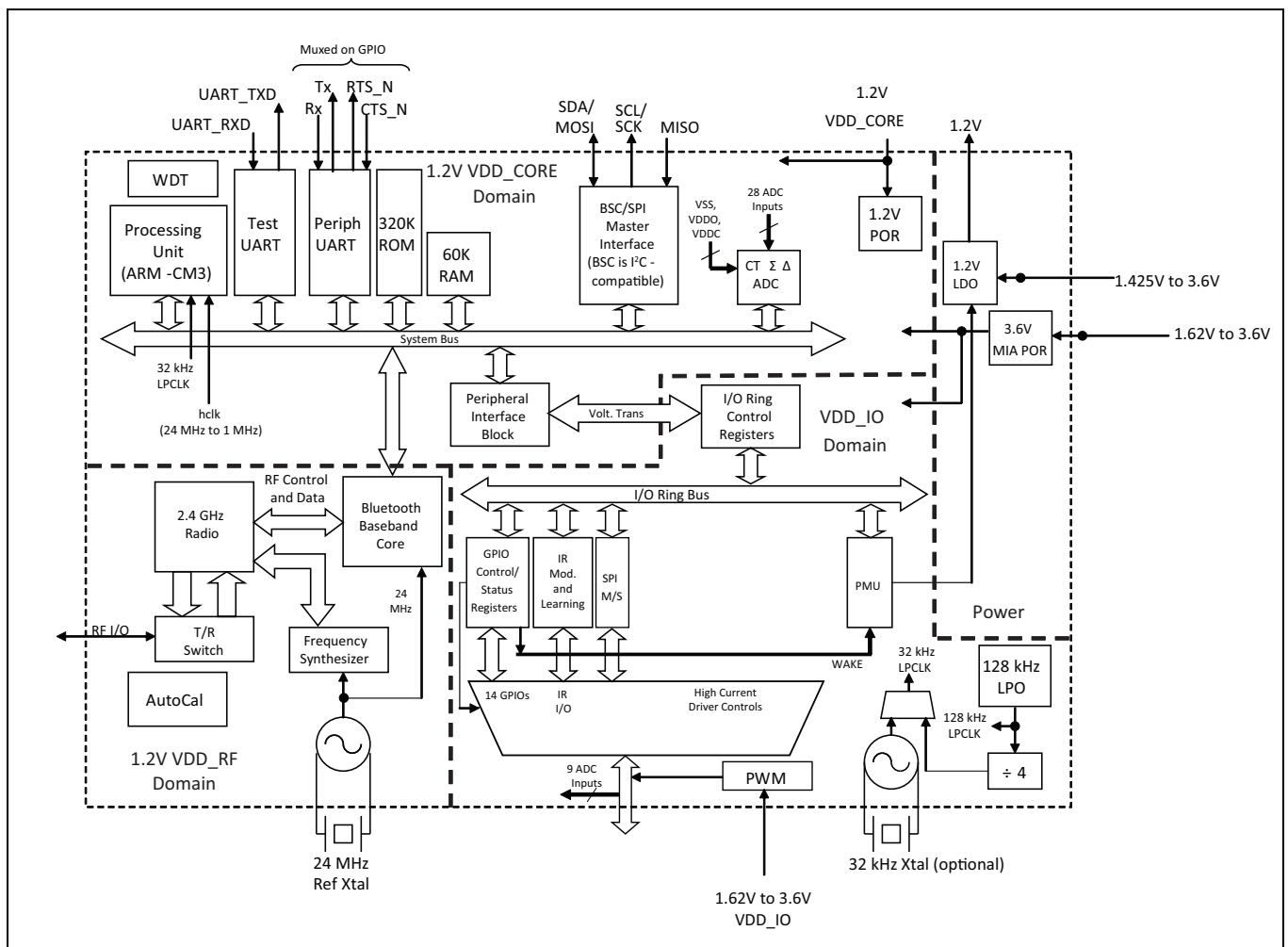

Figure 1 Functional block diagram

Table of contents

Features	1
Table of contents	3
1 Functional Description	4
1.1 Bluetooth® Baseband Core	4
1.2 Infrared modulator	5
1.3 Infrared Learning	7
1.4 ADC Port	7
1.5 Serial peripheral interface (SPI)	8
1.6 Microprocessor unit	9
1.7 Integrated radio transceiver	10
1.8 Peripheral transport unit	11
1.9 Clock frequencies	12
1.10 GPIO port	13
1.11 PWM	14
1.12 Power management unit (PMU)	15
2 Pin information	16
2.1 Pin descriptions	16
2.2 Pin maps	20
2.3 WLCSP pin list and coordinates	22
3 GPIO information	25
4 Specifications	34
4.1 Electrical characteristics	34
4.2 RF specifications	36
4.3 Timing and AC characteristics	38
4.4 Electrostatic discharge (ESD) test models	41
5 Mechanical information	42
5.1 QFN	42
5.2 WLCSP	45
6 Ordering information	46
7 Acronyms and abbreviations	47
Revision history	48

1 Functional Description

1.1 Bluetooth® Baseband Core

The Bluetooth® Baseband Core (BBC) implements all of the time-critical functions required for high performance Bluetooth® operation. The BBC manages the buffering, segmentation, and data routing for all connections. It also buffers data that passes through it, handles data flow control, schedules ACL TX/RX transactions, monitors Bluetooth® slot usage, optimally segments and packages data into baseband packets, manages connection status indicators, and composes and decodes HCI packets. In addition to these functions, it independently handles HCI event types and HCI command types.

The following transmit and receive functions are also implemented in the BBC hardware to increase TX/RX data reliability and security before sending over the air:

- Receive Functions: symbol timing recovery, data deframing, forward error correction (FEC), header error control (HEC), cyclic redundancy check (CRC), data decryption, and data dewatering.
- Transmit Functions: data framing, FEC generation, HEC generation, CRC generation, link key generation, data encryption, and data whitening.

1.1.1 Frequency Hopping Generator

The frequency hopping sequence generator selects the correct hopping channel number depending on the link controller state, Bluetooth® clock, and device address.

1.1.2 E0 Encryption

The encryption key and the encryption engine are implemented using dedicated hardware to reduce software complexity and provide minimal processor intervention.

1.1.3 Link Control Layer

The link control layer is part of the Bluetooth® link control functions that are implemented in dedicated logic in the Link Control Unit (LCU). This layer consists of the Command Controller, which takes software commands, and other controllers that are activated or configured by the Command Controller to perform the link control tasks. Each task performs a different Bluetooth® link controller state. STANDBY and CONNECTION are the two major states. In addition, there are five substates: page, page scan, inquiry, and inquiry scan.

1.1.4 Adaptive Frequency Hopping (AFH)

CYW20736 gathers link quality statistics on a channel-by-channel basis to facilitate channel assessment and channel map selection. The link quality is determined by using both RF and baseband signal processing to provide a more accurate frequency hop map.

1.1.5 Bluetooth® Low Energy profiles

CYW20736 supports Bluetooth® LE, including the following profiles that are supported^[2] in ROM:

- Battery status
- Blood pressure monitor
- Find me
- Heart rate monitor
- Proximity
- Thermometer
- Weight scale
- Time
- AirFuel wireless charging
- Automation profile
- Support for secure OTA

The following additional profiles can be supported^[2] from RAM:

- Blood glucose monitor
- Temperature alarm
- Location
- Custom profile

1.1.6 Test mode support

CYW20736 fully supports Bluetooth® Test mode, as described in the Bluetooth® low energy specification.

1.2 Infrared modulator

CYW20736 includes hardware support for infrared TX. The hardware can transmit both modulated and unmodulated waveforms. For modulated waveforms, hardware inserts the desired carrier frequency into all IR transmis-

Note

2. Full qualification and use of these profiles may require FW updates from Infineon. Some of these profiles are under development/approval at the Bluetooth® SIG and conformity with the final approved version is pending. Contact your supplier for updates and the latest list of profiles.

Functional Description

sions. IR TX can be sourced from firmware-supplied descriptors, a programmable bit, or the peripheral UART transmitter.

If descriptors are used, they include IR ON/OFF state and the duration between 1–32767 μ s. The CYW20736 IR TX firmware driver inserts this information in a hardware FIFO and makes sure that all descriptors are played out without a glitch due to underrun (see [Figure 2](#)).

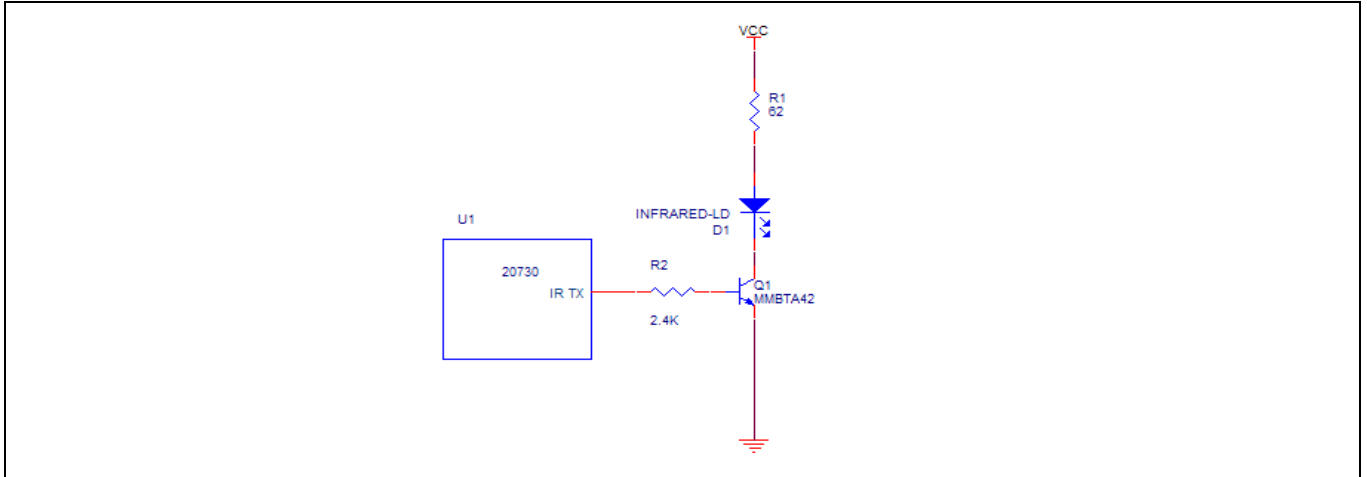

Figure 2 Infrared TX

1.3 Infrared Learning

CYW20736 includes hardware support for infrared learning. The hardware can detect both modulated and unmodulated signals. For modulated signals, the CYW20736 can detect carrier frequencies between 10 kHz–500 kHz and the duration that the signal is present or absent. The CYW20736 firmware driver supports further analysis and compression of learned signal. The learned signal can then be played back through the CYW20736 IR TX subsystem (see [Figure 3](#)).

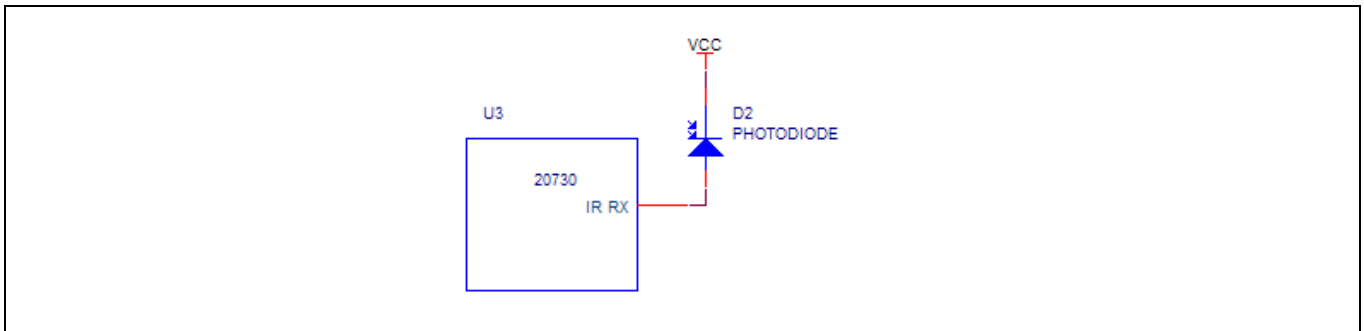

Figure 3 Infrared RX

1.4 ADC Port

CYW20736 contains a 16-bit ADC (effective number of bits is ten).

Additionally:

- There are nine analog input channels in the 32-pin package
- The following GPIOs can be used as ADC inputs:
 - P0
 - P1
 - P8/P33 (select only one)
 - P11
 - P12
 - P13/P28 (select only one)
 - P14/P38 (select only one)
 - P15
 - P32
- The conversion time is 10 μ s
- There is a built-in reference with supply- or bandgap-based reference modes
- The maximum conversion rate is 187 kHz
- There is a rail-to-rail input swing

The ADC consists of an analog ADC core that performs the actual analog-to-digital conversion and digital hardware that processes the output of the ADC core into valid ADC output samples. Directed by the firmware, the digital hardware also controls the input multiplexers that select the ADC input signal V_{inp} and the ADC reference signals V_{ref} .

The ADC input range is selectable by firmware control:

- When an input range of 0–3.6 V is used, the input impedance is 3 M Ω
- When an input range of 0–2.4 V is used, the input impedance is 1.84 M Ω
- When an input range of 0–1.2 V is used, the input impedance is 680 k Ω

ADC modes are defined in s.

Table 1 ADC modes

Mode	ENOB (typical)	Maximum sampling rate (kHz)	Latency ^[3] (μs)	Mode
0	13	5.859	171	0
1	12.6	11.7	85	1
2	12	46.875	21	2
3	11.5	93.75	11	3

Note

3. Setting time after switching channels.

1.5 Serial peripheral interface (SPI)

CYW20736 has two independent SPI interfaces. One is a master-only interface and the other can be either a master or a slave. Each interface has a 16-byte transmit buffer and a 16-byte receive buffer. To support more flexibility for user applications, the CYW20736 has optional I/O ports that can be configured individually and separately for each functional pin as shown in [Table 2](#), [Table 3](#), and [Table 4](#). CYW20736 acts as an SPI master device that supports 1.8 V or 3.3 V SPI slaves. The CYW20736 can also act as an SPI slave device that supports a 1.8 V or 3.3 V SPI master.

Table 2 CYW20736 first SPI set (master mode)

Pin name	SPI_CLK	SPI_MOSI	SPI_MISO	SPI_CS ^[4]
Configured pin name	SCL	SDA	P24	–
	–	–	P26	–
	–	–	P32	–

Note

4. Any GPIO can be used as SPI_CS when SPI is in Master mode.

Table 3 CYW20736 second SPI set (master mode)

Pin name	SPI_CLK	SPI_MOSI	SPI_MISO	SPI_CS ^[5]
Configured pin name	P3	P0	P1	–
	–	P4	P25	–
	P24	P27	–	–

Note

5. Any GPIO can be used as SPI_CS when SPI is in Master mode.

Table 4 CYW20736 second SPI set (slave mode)

Pin name	SPI_CLK	SPI_MOSI	SPI_MISO	SPI_CS
Configured pin name	P3	P0	P1	P2
	–	P27	–	–
	P24	P33	P25	P26
	–	–	–	P32

1.6 Microprocessor unit

The CYW20736 microprocessor unit (μ PU) executes software from the link control (LC) layer up to the application layer components. The microprocessor is based on an Arm® Cortex®-M3, 32-bit RISC processor with embedded ICE-RT debug and JTAG interface units. The μ PU has 320 KB of ROM for program storage and boot-up, 60 KB of RAM for scratch-pad data, and patch RAM code. The SoC has a total storage of 380 KB, including RAM and ROM.

The internal boot ROM provides power-on reset (POR) flexibility, which enables the same device to be used in different HID applications with an external serial EEPROM or with an external serial flash memory. At power-up, the lowest layer of the protocol stack is executed from the internal ROM memory.

External patches may be applied to the ROM-based firmware to provide flexibility for bug fixes and feature additions. The device can also support the integration of user applications.

1.6.1 EEPROM interface

CYW20736 provides a Broadcom serial control (BSC) master interface. BSC is programmed by the CPU to generate four types of bus transfers: read-only, write-only, combined read/write, and combined write/read. BSC supports both low-speed and fast mode devices. BSC is compatible with an NXP I²C slave device, except that master arbitration (multiple I²C masters contending for the bus) is not supported.

The EEPROM can contain customer application configuration information including application code, configuration data, patches, pairing information, BD_ADDR, baud rate, SDP service record, and file system information used for code.

The native support for the Microchip 24LC128, Microchip 24AA128, and ST Micro M24128-BR is included.

1.6.2 Serial flash interface

CYW20736 includes an SPI master controller that can be used to access serial flash memory. The SPI master contains an AHB slave interface, transmit and receive FIFOs, and the SPI core PHY logic.

The devices natively supported include the following:

- Atmel AT25BCM512B
- MXIC MX25V512ZUI-20G

1.6.3 Internal reset

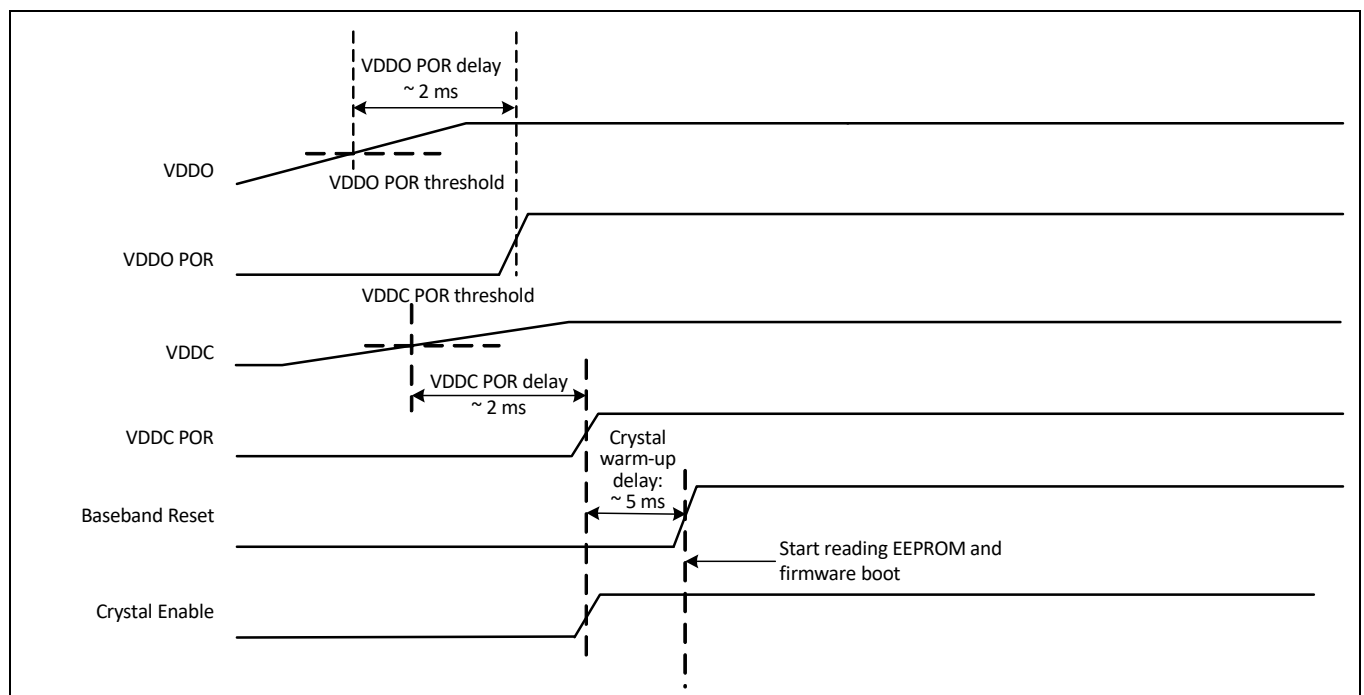

Figure 4 Internal reset timing

1.6.4 External reset

CYW20736 has an integrated power-on reset circuit that completely resets all circuits to a known power-on state. An external active low reset signal, RESET_N, can be used to put CYW20736 in the reset state. The RESET_N pin has an internal pull-up resistor and, in most applications, it does not require that anything be connected to it. RESET_N should only be released after the VDDO supply voltage level has been stabilized.

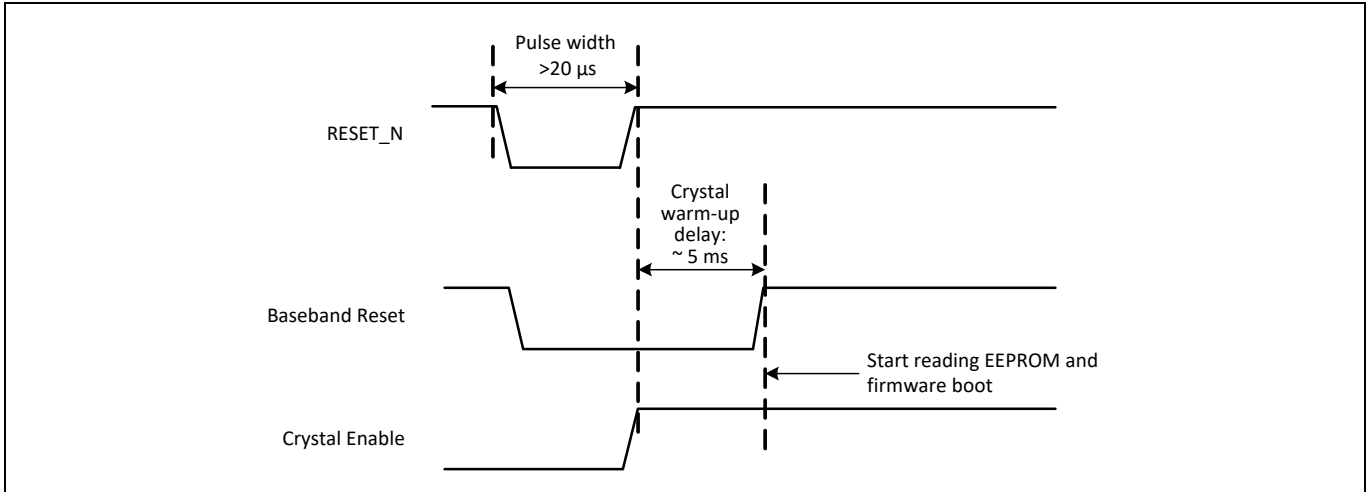

Figure 5 External reset timing

1.7 Integrated radio transceiver

CYW20736 has an integrated radio transceiver that is optimized for 2.4 GHz Bluetooth® wireless systems. It has been designed to provide low-power, low cost, and robust communications for applications operating in the globally available 2.4 GHz unlicensed ISM band. It is fully compliant with Bluetooth® Radio Specification 4.0 and meets or exceeds the requirements to provide the highest communication link quality of service.

1.7.1 Transmitter path (TX)

CYW20736 features a fully integrated transmitter. The baseband transmit data is GFSK modulated in the 2.4 GHz ISM band.

1.7.2 Digital modulator

The digital modulator performs the data modulation and filtering required for the GFSK signal. The fully digital modulator minimizes any frequency drift or anomalies in the modulation characteristics of the transmitted signal.

1.7.3 Power amplifier (PA)

CYW20736 has an integrated power amplifier (PA) that can transmit up to +4 dBm for class 2 operation.

1.7.4 Receiver path (RX)

The RX uses a low IF scheme to downconvert the received signal for demodulation in the digital demodulator and bit synchronizer. The receiver path provides a high degree of linearity, an extended dynamic range, and high-order, on-chip channel filtering to ensure reliable operation in the noisy 2.4 GHz ISM band. The front-end topology, which has built-in out-of-band attenuation, enables the CYW20736 to be used in most applications without off-chip filtering.

1.7.5 Digital demodulator and bit synchronizer

The digital demodulator and bit synchronizer take the low-IF received signal and perform an optimal frequency tracking and bit synchronization algorithm.

1.7.6 Receiver signal strength indicator (RSSI)

The radio portion of the CYW20736 provides a RSSI to the baseband. This enables the controller to take part in a Bluetooth® power-controlled link by providing a metric of its own receiver signal strength to determine whether the transmitter should increase or decrease its output power.

1.7.7 Local oscillator (LO)

The LO provides fast frequency hopping (1600 hops/second) across the 79 maximum available channels. CYW20736 uses an internal loop filter.

1.7.8 Calibration

CYW20736 radio transceiver features a self-contained automated calibration scheme. No user interaction is required during normal operation or during manufacturing to provide optimal performance. Calibration compensates for filter, matching network, and amplifier gain and phase characteristics to yield radio performance within 2% of what is optimal. Calibration takes process and temperature variations into account, and it takes place transparently during normal operation and hop setting times.

1.7.9 Internal LDO regulator

CYW20736 has an integrated 1.2 V LDO regulator that provides power to the digital and RF circuits. The 1.2 V LDO regulator operates from a 1.425 V to 3.63 V input supply with a 30 mA maximum load current.

Note Always place the decoupling capacitors near the pins as closely together as possible.

1.8 Peripheral transport unit

1.8.1 Broadcom serial communications interface

CYW20736 provides a 2-pin master BSC interface, which can be used to retrieve configuration information from an external EEPROM or to communicate with peripherals such as track-ball or touch-pad modules, and motion tracking ICs used in mouse devices. The BSC interface is compatible with I²C slave devices. The BSC does not support multimaster capability or flexible wait-state insertion by either master or slave devices.

The following transfer clock rates are supported by the BSC:

- 100 kHz
- 400 kHz
- 800 kHz (not a standard I²C-compatible speed)
- 1 MHz (compatibility with high-speed I²C-compatible devices is not guaranteed)

The following transfer types are supported by the BSC:

- Read (up to 16 bytes can be read)
- Write (up to 16 bytes can be written)
- Read-then-Write (up to 16 bytes can be read and up to 16 bytes can be written)
- Write-then-Read (up to 16 bytes can be written and up to 16 bytes can be read)

Hardware controls the transfers, requiring minimal firmware setup and supervision.

The clock pin (SCL) and data pin (SDA) are both open-drain I/O pins. Pull-up resistors external to CYW20736 are required on both the SCL and SDA pins for proper operation.

1.8.2 UART interface

The UART is a standard 2-wire interface (RX and TX) and has adjustable baud rates from 9600 bps to 1.5 Mbps. The baud rate can be selected via a vendor-specific UART HCI command. The interface supports the Bluetooth® 3.0 UART HCI (H5) specification. The default baud rate for H5 is 115.2 kbaud.

Both HIGH and LOW baud rates can be supported by running the UART clock at 24 MHz.

The CYW20736 UART operates correctly with the host UART as long as the combined baud rate error of the two devices is within $\pm 5\%$.

1.9 Clock frequencies

CYW20736 is set with crystal frequency of 24 MHz.

1.9.1 Crystal oscillator

The crystal oscillator requires a crystal with an accuracy of ± 20 ppm as defined by the Bluetooth® specification. Two external load capacitors in the range of 5 pF to 30 pF (see [Figure 6](#)) are required to work with the crystal oscillator. The selection of the load capacitors is crystal-dependent. [Table 5](#) shows the recommended crystal specifications.

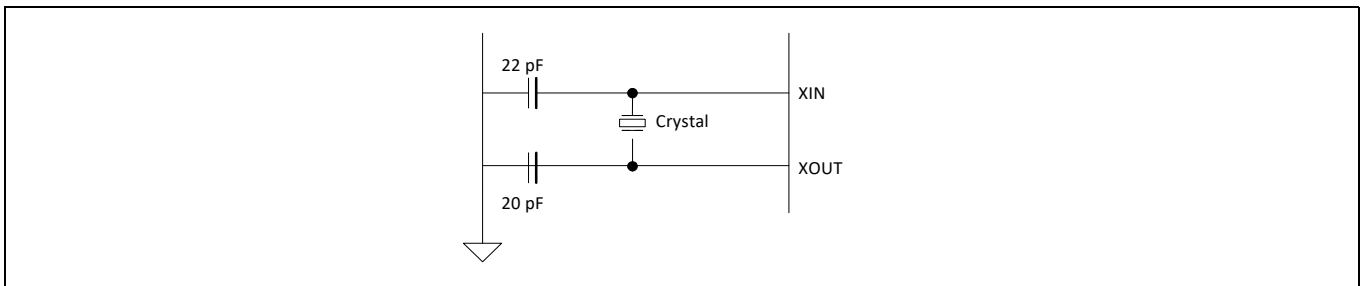

Figure 6 Recommended oscillator configuration – 12 pF load crystal

[Table 5](#) shows the recommended crystal specifications.

Table 5 Reference crystal electrical specifications

Parameter	Conditions	Min	Typ	Max	Unit
Nominal frequency	–	–	24.000	–	MHz
Oscillation mode	–	Fundamental			–
Frequency tolerance	@25°C	–	± 10	–	ppm
Tolerance stability over temp	@0°C to +70°C	–	± 10	–	ppm
Equivalent series resistance	–	–	–	60	Ω
Load capacitance	–	–	12	–	pF
Operating temperature range	–	0	–	+70	°C
Storage temperature range	–	–40	–	+125	°C
Drive level	–	–	–	200	$\mu\Omega$
Aging	–	–	–	± 10	ppm/year
Shunt capacitance	–	–	–	2	pF

1.9.2 Peripheral block

The peripheral blocks of CYW20736 all run from a single 128 kHz low-power RC oscillator. The oscillator can be turned on at the request of any of the peripherals. If the peripheral is not enabled, it shall not assert its clock request line.

The keyboard scanner is a special case, in that it may drop its clock request line even when enabled, and then reassert the clock request line if a keypress is detected.

1.9.3 32 kHz crystal oscillator

Figure 7 shows the 32 kHz crystal (XTAL) oscillator with external components and **Table 6** lists the oscillator's characteristics. It is a standard Pierce oscillator using a comparator with hysteresis on the output to create a single-ended digital output. The hysteresis was added to eliminate any chatter when the input is around the threshold of the comparator and is ~100 mV. This circuit can be operated with a 32 kHz or 32.768 kHz crystal oscillator or be driven with a clock input at similar frequency. The default component values are: R1 = 10 MΩ, C1 = C2 = ~10 pF. The values of C1 and C2 are used to fine-tune the oscillator.

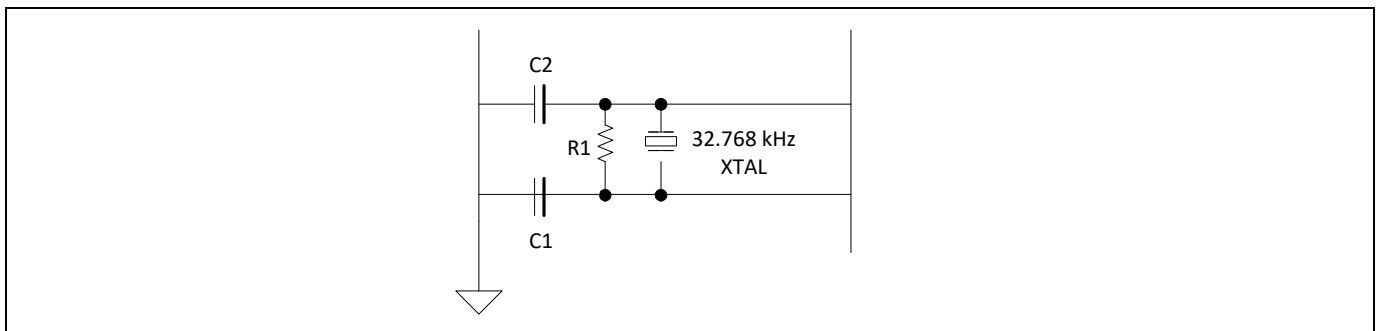

Figure 7 32 kHz oscillator block diagram

Table 6 XTAL oscillator characteristics

Parameter	Symbol	Conditions	Min	Typ	Max	Unit
Output frequency	F_{oscout}	–	–	32.768	–	kHz
Frequency tolerance	–	Crystal dependent	–	100	–	ppm
Start-up time	$T_{startup}$	–	–	–	500	ms
XTAL drive level	P_{drv}	For crystal selection	0.5	–	–	$\mu\Omega$
XTAL series resistance	R_{series}	For crystal selection	–	–	70	kΩ
XTAL shunt capacitance	C_{shunt}	For crystal selection	–	–	1.3	pF

1.10 GPIO port

CYW20736 has fourteen general-purpose I/Os (GPIOs) in the 32-pin package. All GPIOs support programmable pull-up and pull-down resistors, and all support a 2 mA drive strength except P26, P27, and P28, which provide a 16 mA drive strength at 3.3 V supply.

The following GPIOs are available:

- P0–P4
- P8/P33 (Dual bonded, only one of two is available)
- P11/P27 (Dual bonded, only one of two is available)
- P12/P26 (Dual bonded, only one of two is available)
- P13/P28 (Dual bonded, only one of two is available)

Functional Description

- P14/P38 (Dual bonded, only one of two is available)
- P15
- P24
- P25
- P32

For a description of all GPIOs, see [Table 10](#).

1.11 PWM

CYW20736 has four internal PWM channels. The PWM module is described as follows:

- PWM0–3
- The following GPIOs can be mapped as PWMs:
 - P26
 - P27
 - P14/P28 (Dual bonded, only one of two is available)
 - P13
- Each of the PWM channels, PWM0–3, contains the following registers:
 - 10-bit initial value register (read/write)
 - 10-bit toggle register (read/write)
 - 10-bit PWM counter value register (read)
- The PWM configuration register is shared among PWM0–3 (read/write). This 12-bit register is used:
 - To configure each PWM channel
 - To select the clock of each PWM channel
 - To change the phase of each PWM channel

Figure 8 shows the structure of one PWM channel.

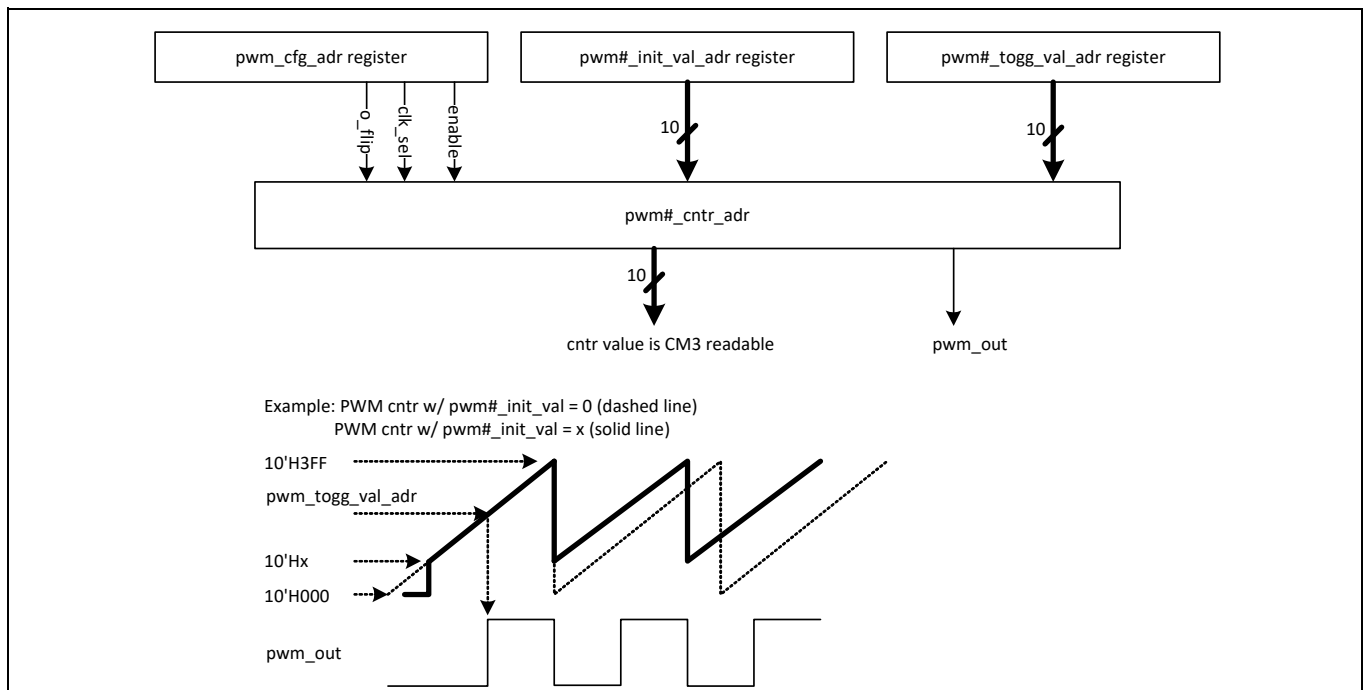

Figure 8 PWM channel block diagram

1.12 Power management unit (PMU)

The PMU provides power management features that can be invoked by software through power management registers or packet-handling in the baseband core.

1.12.1 RF power management

The BBC generates power-down control signals for the transmit path, receive path, PLL, and power amplifier to the 2.4 GHz transceiver, which then processes the power-down functions accordingly.

1.12.2 Host controller power management

The power is automatically managed by the firmware based on input device activity. As a power-saving task, the firmware controls the disabling of the on-chip regulator when in deep sleep mode.

1.12.3 BBC power management

There are several low-power operations for the BBC:

- Physical layer packet handling turns RF OIN and OFF dynamically within packet TX and RX.
- Bluetooth®-specified low-power connection mode. While in these low-power connection modes, the CYW20736 runs on the Low Power Oscillator and wakes up after a predefined time period.

CYW20736 automatically adjusts its power dissipation based on user activity. The following power modes are supported:

- Active mode
- Idle mode
- Sleep mode
- HIDEOFF (Deep Sleep) mode
- Timed Deep Sleep mode

CYW20736 transitions to the next lower state after a programmable period of user inactivity. The Busy mode is immediately entered when user activity resumes.

In HIDEOFF (Deep Sleep) mode, CYW20736 baseband and core are powered off by disabling power to LDOOUT. The VDDO domain remains powered up and will turn the remainder of the chip on when it detects user events. This mode minimizes chip power consumption and is intended for long periods of inactivity.

2 Pin information

2.1 Pin descriptions

Table 7 provides pin descriptions for the QFN package.

Table 7 QFN package pin descriptions

Pin number	Pin name	I/O	Power domain	Description
Radio I/O				
6	RF	I/O	VDD_RF	RF antenna port
RF power supplies				
4	VDDIF	I	VDD_RF	IFPLL power supply
5	VDDFE	I	VDD_RF	RF front-end supply
7	VDDVCO	I	VDD_RF	VCO, LOGEN supply
8	VDDPLL	I	VDD_RF	RFPLL and crystal oscillator supply
Power supplies				
11	VDDC	I	VDDC	Baseband core supply
28	VDDO	I	VDDO	I/O pad and core supply
14	VDDM	I	VDDM	I/O pad supply
Clock generator and crystal interface				
9	XTALI	I	VDD_RF	Crystal oscillator input. See Crystal oscillator on page 12 for options.
10	XTALO	O	VDD_RF	Crystal oscillator output.
1	XTALI32K	I	VDDO	Low-power oscillator (LPO) input is used. Alternative Function: • P11 • P27
32	XTALO32K	O	VDDO	Low-power oscillator (LPO) output. Alternative Function: • P12 • P26
Core				
18	RESET_N	I/O PU	VDDO	Active-low system reset with open-drain output & internal pull-up resistor
17	TMC	I	VDDO	Test mode control High: test mode Connect to GND if not used.
UART				
12	UART_RXD	I	VDDM	UART serial input – Serial data input for the HCI UART interface. Leave unconnected if not used. Alternative function: GPIO3
13	UART_TXD	O, PU	VDDM	UART serial output – Serial data output for the HCI UART interface. Leave unconnected if not used. Alternative Function: GPIO2

Pin information

Table 7 QFN package pin descriptions (continued)

Pin number	Pin name	I/O	Power domain	Description
BSC				
15	SDA	I/O, PU	VDDM	Data signal for an external I ² C device. Alternative function: <ul style="list-style-type: none"> • SPI_1: MOSI (master only) • GPIO0 • CTS
16	SCL	I/O, PU	VDDM	Clock signal for an external I ² C device. Alternative function: <ul style="list-style-type: none"> • SPI_1: SPI_CLK (master only) • GPIO1 • RTS
LDO regulator power supplies				
2	LDOIN	I	N/A	Battery input supply for the LDO
3	LDOOUT	O	N/A	LDO output

Table 8 provides pin descriptions for the WLCSP package. The table is ordered by pin name.

Table 8 WLCSP package pin descriptions

Pin numbers	Pin name	Type	Power domain	Description
57	AVSS	I	AVSS	Analog ground
69	FEVDD	I	FEVDD	RF front-end supply
70	FEVSS	I	VSS	Ground
67	IFVDD	I	IFVDD	IF PLL power supply
54, 68, 71, 72	IFVSS	I	VSS	Ground
76	PLLVDD	I	PLLVDD	RF PLL and crystal oscillator supply
79	PLLVSS	I	VSS	Ground

Pin information

Table 8 WLCSP package pin descriptions (continued)

Pin numbers	Pin name	Type	Power domain	Description
21	P0	I	VDDO	General purpose I/O (See Table 11)
26	P1	I	VDDO	
22	P2	I	VDDO	
13	P3	I	VDDO	
31	P4	I	VDDO	
14	P5	I	VDDO	
27	P6	I	VDDO	
18	P7	I	VDDO	
36	P8	I	VDDO	
63	P9	I	VDDO	
53	P10	I	VDDO	
66	P11	I	VDDO	
55	P12	I	VDDO	
20	P13	I	VDDO	
35	P14	I	VDDO	
52	P15	I	VDDO	
32	P16	I	VDDO	
23	P17	I	VDDO	
41	P18	I	VDDO	
28	P19	I	VDDO	
33	P20	I	VDDO	
43	P21	I	VDDO	
15	P22	I	VDDO	
48	P23	I	VDDO	
47	P24	I	VDDO	
19	P25	I	VDDO	
30	P26	I	VDDO	
25	P27	I	VDDO	
49	P28	I	VDDO	
44	P29	I	VDDO	
50	P30	I	VDDO	
39	P31	I	VDDO	
38	P32	I	VDDO	
46	P33	I	VDDO	
34	P34	I	VDDO	
29	P35	I	VDDO	
62	P36	I	VDDO	
64	P37	I	VDDO	
24	P38	I	VDDO	
51	P39	I	VDDO	

Table 8 **WLCSPP package pin descriptions** (continued)

Pin numbers	Pin name	Type	Power domain	Description
73	RF	I/O	VDD_RF	RF antenna port
16	RST_N	I/O PU	VDDO	Active-low system reset with open-drain output & internal pull-up resistor
2	SCL	I/O, PU	VDDM	Clock signal for an external I ² C device. Alternative function: <ul style="list-style-type: none"> • SPI_1: SPI_CLK (master only) • GPIO1 • RTS
7	SDA	I/O, PU	VDDM	Data signal for an external I ² C device. Alternative function: <ul style="list-style-type: none"> • SPI_1: MOSI (master only) • GPIO0 • CTS
11	TMC	I	VDDO	Test mode control High: test mode Connect to GND if not used.
10	UART_RXD	I	VDDM	UART serial input – Serial data input for the HCI UART interface. Leave unconnected if not used. Alternative function: GPIO3
9	UART_TXD	O, PU	VDDM	UART serial output – Serial data output for the HCI UART interface. Leave unconnected if not used. Alternative Function: GPIO2
77, 80	VCOVDD	I	VCOVDD	VCO and LO generator supply
74	VCOVSS	I	N/A	Ground
1, 4	VDDC	I	VDDC	Baseband core supply
3	VDDM	I	VDDM	I/O pad supply
17, 37, 45, 58	VDDO	I	VDDO	I/O pad and core supply
65	VREG	O	VREG	Internal LDO regulator output
60	VR3V	I	N/A	Internal LDO regulator input
5, 6, 8	VSSC	I	N/A	Ground
12, 40, 59	VSSO	I	N/A	Ground
42	VSS0	I	N/A	Ground
75	XIN	I	VDD_RF	Crystal oscillator input. See Crystal oscillator on page 12 for options.
78	XOUT	O	VDD_RF	Crystal oscillator output
61	XTAL32KI	I	VDDO	Low-power oscillator (LPO) input is used
56	XTAL32KO	O	VDDO	Low-power oscillator (LPO) output

2.2 Pin maps

Figure 9 shows the ball map of the QFN package.

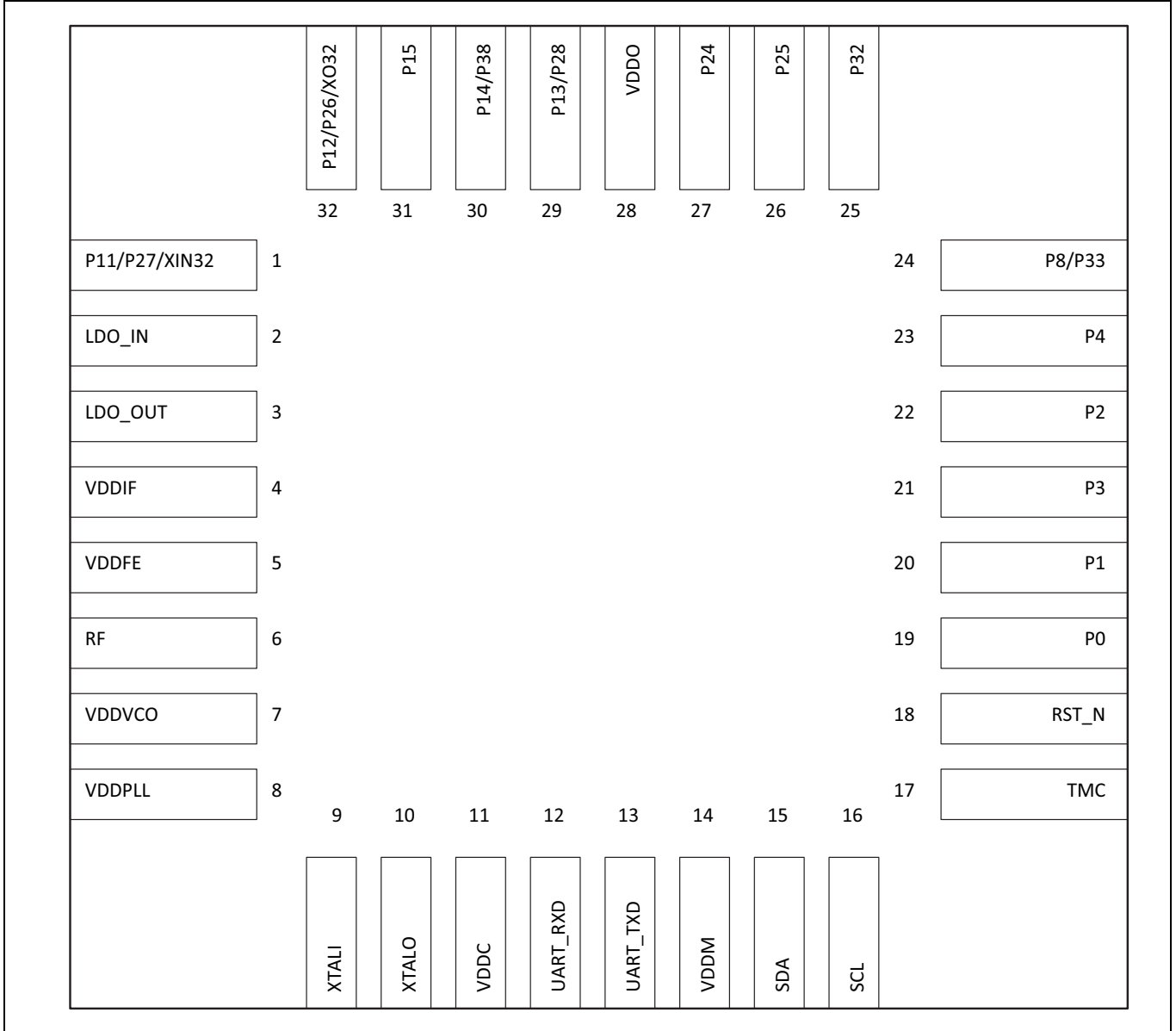

Figure 9 32-pin QFN ball map

Figure 10 shows the bump map of the WLCSP package.

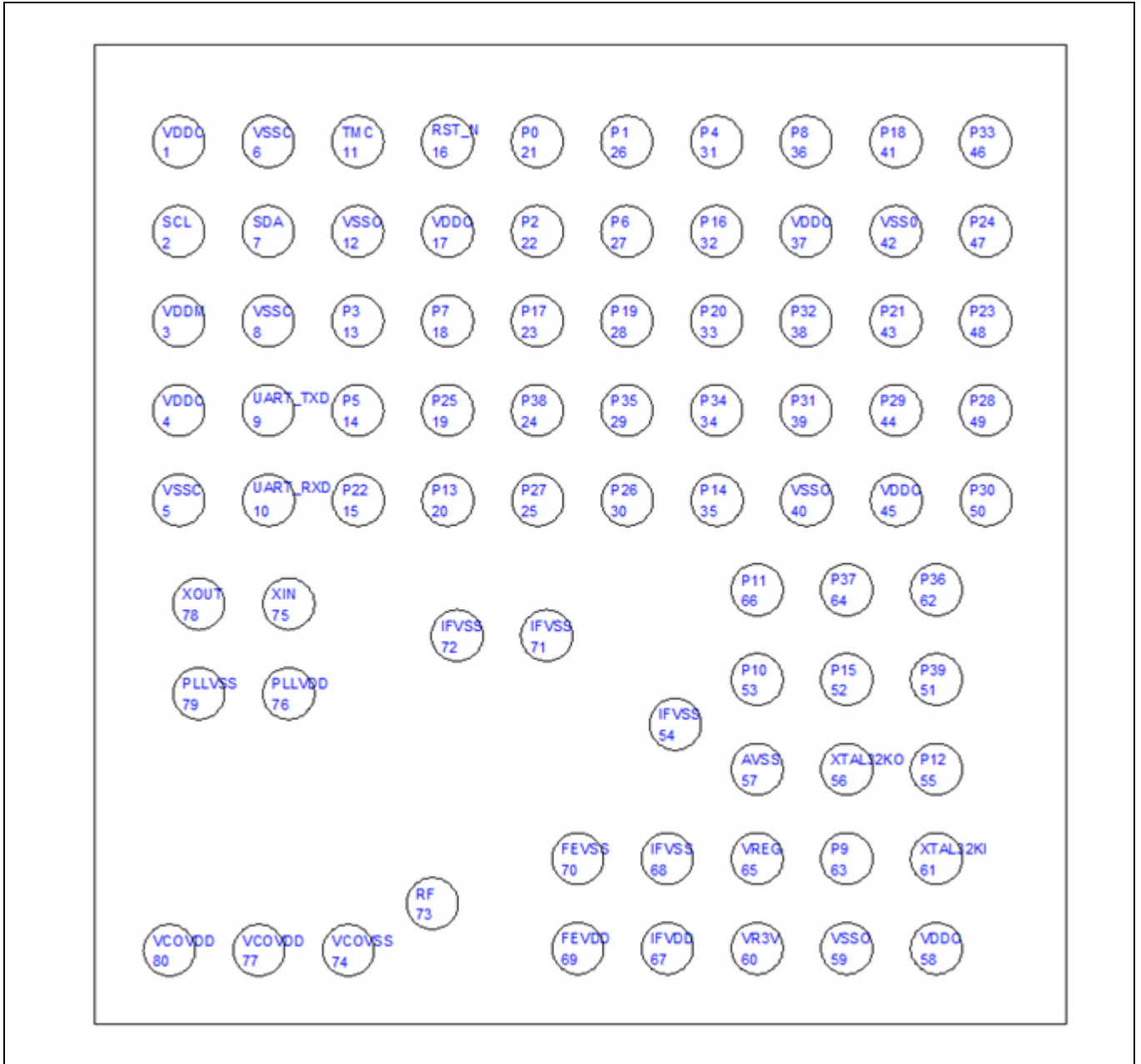

Figure 10 80-pin WLCSP bump map—top view of package with bump facing down

2.3 WLCSP pin list and coordinates

Table 9 provides the WLCSP pin list and coordinates.

Table 9 WLCSP pin list and coordinates

Bump #	Net name	Package bottom view (bumps facing up) package center (0,0)		Package top view (bumps facing down) package center (0,0)	
		X coordinate	Y coordinate	X coordinate	Y coordinate
1	VDDC	-895.5	-877.2587	-895.5	877.2587
2	SCL	-895.5	-677.2587	-895.5	677.2587
3	VDDM	-895.5	-477.2587	-895.5	477.2587
4	VDDC	-895.5	-277.2587	-895.5	277.2587
5	VSSC	-895.5	-77.2587	-895.5	77.2587
6	VSSC	-695.5	-877.2587	-695.5	877.2587
7	SDA	-695.5	-677.2587	-695.5	677.2587
8	VSSC	-695.5	-477.2587	-695.5	477.2587
9	UART_TXD	-695.5	-277.2587	-695.5	277.2587
10	UART_RXD	-695.5	-77.2587	-695.5	77.2587
11	TMC	-495.5	-877.2587	-495.5	877.2587
12	VSSO	-495.5	-677.2587	-495.5	677.2587
13	P3	-495.5	-477.2587	-495.5	477.2587
14	P5	-495.5	-277.2587	-495.5	277.2587
15	P22	-495.5	-77.2587	-495.5	77.2587
16	RST_N	-295.5	-877.2587	-295.5	877.2587
17	VDDO	-295.5	-677.2587	-295.5	677.2587
18	P7	-295.5	-477.2587	-295.5	477.2587
19	P25	-295.5	-277.2587	-295.5	277.2587
20	P13	-295.5	-77.2587	-295.5	77.2587
21	P0	-95.5	-877.2587	-95.5	877.2587
22	P2	-95.5	-677.2587	-95.5	677.2587
23	P17	-95.5	-477.2587	-95.5	477.2587
24	P38	-95.5	-277.2587	-95.5	277.2587
25	P27	-95.5	-77.2587	-95.5	77.2587
26	P1	104.5	-877.2587	104.5	877.2587
27	P6	104.5	-677.2587	104.5	677.2587
28	P19	104.5	-477.2587	104.5	477.2587
29	P35	104.5	-277.2587	104.5	277.2587
30	P26	104.5	-77.2587	104.5	77.2587
31	P4	304.5	-877.2587	304.5	877.2587
32	P16	304.5	-677.2587	304.5	677.2587
33	P20	304.5	-477.2587	304.5	477.2587
34	P34	304.5	-277.2587	304.5	277.2587
35	P14	304.5	-77.2587	304.5	77.2587
36	P8	504.5	-877.2587	504.5	877.2587

Pin information

Table 9 WLCSP pin list and coordinates (continued)

Bump #	Net name	Package bottom view (bumps facing up) package center (0,0)		Package top view (bumps facing down) package center (0,0)	
		X coordinate	Y coordinate	X coordinate	Y coordinate
37	VDDO	504.5	-677.2587	504.5	677.2587
38	P32	504.5	-477.2587	504.5	477.2587
39	P31	504.5	-277.2587	504.5	277.2587
40	VSSO	504.5	-77.2587	504.5	77.2587
41	P18	704.5	-877.2587	704.5	877.2587
42	VSS0	704.5	-677.2587	704.5	677.2587
43	P21	704.5	-477.2587	704.5	477.2587
44	P29	704.5	-277.2587	704.5	277.2587
45	VDDO	704.5	-77.2587	704.5	77.2587
46	P33	904.5	-877.2587	904.5	877.2587
47	P24	904.5	-677.2587	904.5	677.2587
48	P23	904.5	-477.2587	904.5	477.2587
49	P28	904.5	-277.2587	904.5	277.2587
50	P30	904.5	-77.2587	904.5	77.2587
51	P39	794	322.7413	794	-322.7413
52	P15	594	322.7413	594	-322.7413
53	P10	394	322.7413	394	-322.7413
54	IFVSS	211.14	422.7413	211.14	-422.7413
55	P12	794	522.7413	794	-522.7413
56	XTAL32KO	594	522.7413	594	-522.7413
57	AVSS	394	522.7413	394	-522.7413
58	VDDO	794	922.7413	794	-922.7413
59	VSSO	594	922.7413	594	-922.7413
60	VR3V	394	922.7413	394	-922.7413
61	XTAL32KI	794	722.7413	794	-722.7413
62	P36	794	122.7413	794	-122.7413
63	P9	594	722.7413	594	-722.7413
64	P37	594	122.7413	594	-122.7413
65	VREG	394	722.7413	394	-722.7413
66	P11	394	122.7413	394	-122.7413
67	IFVDD	194	922.7413	194	-922.7413
68	IFVSS	194	722.7413	194	-722.7413
69	FEVDD	-6	922.7413	-6	-922.7413
70	FEVSS	-6	722.7413	-6	-722.7413
71	IFVSS	-75.35	224.6363	-75.35	-224.6363
72	IFVSS	-275.35	224.6363	-275.35	-224.6363
73	RF	-330.025	822.7413	-330.025	-822.7413
74	VCOVSS	-517.5	927.0313	-517.5	-927.0313

Table 9 WLCSP pin list and coordinates *(continued)*

Bump #	Net name	Package bottom view (bumps facing up) package center (0,0)		Package top view (bumps facing down) package center (0,0)	
		X coordinate	Y coordinate	X coordinate	Y coordinate
75	XIN	-651.09	154.5313	-651.09	-154.5313
76	PLLVDD	-651.09	354.5313	-651.09	-354.5313
77	VCOVDD	-717.5	927.0313	-717.5	-927.0313
78	XOUT	-851.09	154.5313	-851.09	-154.5313
79	PLLVSS	-851.09	354.5313	-851.09	-354.5313
80	VCOVDD	-917.5	927.0313	-917.5	-927.0313

3 GPIO information

Table 10 provides the GPIO alternate function descriptions for the QFN package.

Table 10 QFN package GPIO pin descriptions^[6]

Pin number	Pin name	Default direction	After POR state	Power domain	Alternate function description
19	P0	Input	Input floating	VDDO	<ul style="list-style-type: none"> • GPIO: P0 • A/D converter input • Peripheral UART: puart_tx • SPI_2: MOSI (master and slave) • IR_RX • 60Hz_main • Not available during TMC=1
20	P1	Input	Input floating	VDDO	<ul style="list-style-type: none"> • GPIO: P1 • A/D converter input • Peripheral UART: puart_rts • SPI_2: MISO (master and slave) • IR_TX
21	P3	Input	Input floating	VDDO	<ul style="list-style-type: none"> • GPIO: P3 • Peripheral UART: puart_cts • SPI_2: SPI_CLK (master and slave)
22	P2	Input	Input floating	VDDO	<ul style="list-style-type: none"> • GPIO: P2 • Peripheral UART: puart_rx • SPI_2: SPI_CS (slave only) • SPI_2: SPI_MOSI (master only)
23	P4	Input	Input floating	VDDO	<ul style="list-style-type: none"> • GPIO: P4 • Peripheral UART: puart_rx • SPI_2: MOSI (master and slave) • IR_TX
24	P8	Input	Input floating	VDDO	<ul style="list-style-type: none"> • GPIO: P8 • A/D converter input • External T/R switch control: ~tx_pd
	P33	Input	Input floating	VDDO	<ul style="list-style-type: none"> • GPIO: P33 • A/D converter input • SPI_2: MOSI (slave only) • Auxiliary clock output: ACLK1 • Peripheral UART: puart_rx

Note

6. During a power-on reset, all inputs are disabled.

Table 10 QFN package GPIO pin descriptions^[6]

Pin number	Pin name	Default direction	After POR state	Power domain	Alternate function description
1	P11	Input	Input floating	VDDO	<ul style="list-style-type: none"> GPIO: P11 A/D converter input XTALI32K
	P27 PWM1	Input	Input floating	VDDO	<ul style="list-style-type: none"> GPIO: P27 SPI_2: MOSI (master and slave) Current: 16 mA
32	P12	Input	Input floating	VDDO	<ul style="list-style-type: none"> GPIO: P12 A/D converter input XTALO32K
	P26 PWM0	Input	Input floating	VDDO	<ul style="list-style-type: none"> GPIO: P26 SPI_2: SPI_CS (slave only) SPI_1: MISO (master only) Current: 16 mA
29	P13 PWM3	Input	Input floating	VDDO	<ul style="list-style-type: none"> GPIO: P13 A/D converter input
	P28 PWM2	Input	Input floating	VDDO	<ul style="list-style-type: none"> GPIO: P28 A/D converter input LED1 IR_TX Current: 16 mA
30	P14 PWM2	Input	Input floating	VDDO	<ul style="list-style-type: none"> GPIO: P14 A/D converter input
	P38	Input	Input floating	VDDO	<ul style="list-style-type: none"> GPIO: P38 A/D converter input SPI_2: MOSI (master and slave) IR_TX
31	P15	Input	Input floating	VDDO	<ul style="list-style-type: none"> GPIO: P15 A/D converter input IR_RX 60 Hz_main

Note

6. During a power-on reset, all inputs are disabled.

Table 10 QFN package GPIO pin descriptions^[6]

Pin number	Pin name	Default direction	After POR state	Power domain	Alternate function description
27	P24	Input	Input floating	VDDO	<ul style="list-style-type: none"> GPIO: P24 SPI_2: SPI_CLK (master and slave) SPI_1: MISO (master only) Peripheral UART: puart_tx
26	P25	Input	Input floating	VDDO	<ul style="list-style-type: none"> GPIO: P25 SPI_2: MISO (master and slave) Peripheral UART: puart_rx
25	P32	Input	Input floating	VDDO	<ul style="list-style-type: none"> GPIO: P32 A/D converter input SPI_2: SPI_CS (slave only) SPI_1: MISO (master only) Auxiliary clock output: ACLK0 Peripheral UART: puart_tx

Note

6. During a power-on reset, all inputs are disabled.

Table 11 provides the GPIO alternate function descriptions for the WLCSP package.

Table 11 WLCSP package GPIO pin descriptions^[7]

Pin number	Pin name	Default direction	After POR	Power domain	Alternate function description
21	P0	Input	Floating	VDDO	<ul style="list-style-type: none"> GPIO: P0 Keyboard scan input (row): KSI0 A/D converter input Peripheral UART: puart_tx SPI_2: MOSI (master and slave) IR_RX 60 Hz_main Not available during TMC=1
26	P1	Input	Floating	VDDO	<ul style="list-style-type: none"> GPIO: P1 Keyboard scan input (row): KSI1 A/D converter input Peripheral UART: puart_rts SPI_2: MISO (master and slave) IR_TX

Note

7. During a power-on reset, all inputs are disabled.

Table 11 WLCSP package GPIO pin descriptions^[7]

Pin number	Pin name	Default direction	After POR	Power domain	Alternate function description
22	P2	Input	Floating	VDDO	<ul style="list-style-type: none"> GPIO: P2 Keyboard scan input (row): KSI2 Quadrature: QDX0 Peripheral UART: puart_rx SPI_2: SPI_CS (slave only) SPI_2: SPI_MOSI (master only)
13	P3	Input	Floating	VDDO	<ul style="list-style-type: none"> GPIO: P3 Keyboard scan input (row): KSI3 Quadrature: QDX1 Peripheral UART: puart_cts SPI_2: SPI_CLK (master and slave)
31	P4	Input	Floating	VDDO	<ul style="list-style-type: none"> GPIO: P4 Keyboard scan input (row): KSI4 Quadrature: QDY0 Peripheral UART: puart_rx SPI_2: MOSI (master and slave) IR_TX
14	P5	Input	Floating	VDDO	<ul style="list-style-type: none"> GPIO: P5 Keyboard scan input (row): KSI5 Quadrature: QDY1 Peripheral UART: puart_tx SPI_2: MISO (master and slave)
27	P6 PWM2	Input	Floating	VDDO	<ul style="list-style-type: none"> GPIO: P6 Keyboard scan input (row): KSI6 Quadrature: QDZ0 Peripheral UART: puart_rts SPI_2: SPI_CS (slave only) 60Hz_main
18	P7	Input	Floating	VDDO	<ul style="list-style-type: none"> GPIO: P7 Keyboard scan input (row): KSI7 Quadrature: QDZ1 Peripheral UART: puart_cts SPI_2: SPI_CLK (master and slave)

Note

7. During a power-on reset, all inputs are disabled.

Table 11 WLCSP package GPIO pin descriptions^[7]

Pin number	Pin name	Default direction	After POR	Power domain	Alternate function description
36	P8	Input	Floating	VDDO	<ul style="list-style-type: none"> GPIO: P8 Keyboard scan output (column): KSO0 A/D converter input External T/R switch control: ~tx_pd
63	P9	Input	Floating	VDDO	<ul style="list-style-type: none"> GPIO: P9 Keyboard scan output (column): KSO1 A/D converter input External T/R switch control: tx_pd
53	P10 PWM3	Input	Floating	VDDO	<ul style="list-style-type: none"> GPIO: P10 Keyboard scan output (column): KSO2 A/D converter input
66	P11	Input	Floating	VDDO	<ul style="list-style-type: none"> GPIO: P11 Keyboard scan output (column): KSO3 A/D converter input XTALI32K (40-QFN only)
55	P12	Input	Floating	VDDO	<ul style="list-style-type: none"> GPIO: P12 Keyboard scan output (column): KSO4 A/D converter input XTALO32K (40-QFN only)
20	P13 PWM3	Input	Floating	VDDO	<ul style="list-style-type: none"> GPIO: P13 Keyboard scan output (column): KSO5 A/D converter input Alternative Function: P28
35	P14 PWM2	Input	Floating	VDDO	<ul style="list-style-type: none"> GPIO: P14 Keyboard scan output (column): KSO6 A/D converter input
52	P15	Input	Floating	VDDO	<ul style="list-style-type: none"> GPIO: P15 Keyboard scan output (column): KSO7 A/D converter input IR_RX 60Hz_main Alternative Function: P26

Note

7. During a power-on reset, all inputs are disabled.

GPIO information

Table 11 WLCSP package GPIO pin descriptions^[7]

Pin number	Pin name	Default direction	After POR	Power domain	Alternate function description
32	P16	Input	Floating	VDDO	<ul style="list-style-type: none"> GPIO: P16 Keyboard scan output (column): KSO8
23	P17	Input	Floating	VDDO	<ul style="list-style-type: none"> GPIO: P17 Keyboard scan output (column): KSO9 A/D converter input
41	P18	Input	Floating	VDDO	<ul style="list-style-type: none"> GPIO: P18 Keyboard scan output (column): KSO10 A/D converter input
28	P19	Input	Floating	VDDO	<ul style="list-style-type: none"> GPIO: P19 Keyboard scan output (column): KSO11 A/D converter input
33	P20	Input	Floating	VDDO	<ul style="list-style-type: none"> GPIO: P20 Keyboard scan output (column): KSO12 A/D converter input
43	P21	Input	Floating	VDDO	<ul style="list-style-type: none"> GPIO: P21 Keyboard scan output (column): KSO13 A/D converter input
15	P22	Input	Floating	VDDO	<ul style="list-style-type: none"> GPIO: P22 Keyboard scan output (column): KSO14 A/D converter input
48	P23	Input	Floating	VDDO	<ul style="list-style-type: none"> GPIO: P23 Keyboard scan output (column): KSO15 A/D converter input
47	P24	Input	Floating	VDDO	<ul style="list-style-type: none"> GPIO: P24 Keyboard scan output (column): KSO16 SPI_2: SPI_CLK (master and slave) SPI_1: MISO (master only) Peripheral UART: puart_tx

Note

7. During a power-on reset, all inputs are disabled.

Table 11 WLCSP package GPIO pin descriptions^[7]

Pin number	Pin name	Default direction	After POR	Power domain	Alternate function description
19	P25	Input	Floating	VDDO	<ul style="list-style-type: none"> GPIO: P25 Keyboard scan output (column): KSO17 SPI_2: MISO (master and slave) Peripheral UART: puart_rx
30	P26 PWM0	Input	Floating	VDDO	<ul style="list-style-type: none"> GPIO: P26 Keyboard scan output (column): KSO18 SPI_2: SPI_CS (slave only) SPI_1: MISO (master only) Optical control output: QOC0 Current: 16 mA Alternative function: P15
25	P27 PWM1	Input	Floating	VDDO	<ul style="list-style-type: none"> GPIO: P27 Keyboard scan output (column): KSO19 SPI_2: MOSI (master and slave) Optical control output: QOC1 Current: 16 mA
49	P28 PWM2	Input	Floating	VDDO	<ul style="list-style-type: none"> GPIO: P28 Optical control output: QOC2 A/D converter input LED1 Current: 16 mA Alternative function: P13
44	P29 PWM3	Input	Floating	VDDO	<ul style="list-style-type: none"> GPIO: P29 Optical control output: QOC3 A/D converter input LED2 Current: 16 mA
50	P30	Input	Floating	VDDO	<ul style="list-style-type: none"> GPIO: P30 A/D converter input Pairing button pin in default FW Peripheral UART: puart_rts

Note

7. During a power-on reset, all inputs are disabled.

Table 11 WLCSP package GPIO pin descriptions^[7]

Pin number	Pin name	Default direction	After POR	Power domain	Alternate function description
39	P31	Input	Floating	VDDO	<ul style="list-style-type: none"> GPIO: P31 A/D converter input EEPROM WP pin in default FW Peripheral UART: puart_tx
38	P32	Input	Floating	VDDO	<ul style="list-style-type: none"> GPIO: P32 A/D converter input Quadrature: QDX0 SPI_2: SPI_CS (slave only) SPI_1: MISO (master only) Auxiliary clock output: ACLK0 Peripheral UART: puart_tx
46	P33	Input	Floating	VDDO	<ul style="list-style-type: none"> GPIO: P33 A/D converter input Quadrature: QDX1 SPI_2: MOSI (slave only) Auxiliary clock output: ACLK1 Peripheral UART: puart_rx
34	P34	Input	Floating	VDDO	<ul style="list-style-type: none"> GPIO: P34 A/D converter input Quadrature: QDY0 Peripheral UART: puart_rx External T/R switch control: tx_pd
29	P35	Input	Floating	VDDO	<ul style="list-style-type: none"> GPIO: P35 A/D converter input Quadrature: QDY1 Peripheral UART: puart_cts
62	P36	Input	Floating	VDDO	<ul style="list-style-type: none"> GPIO: P36 A/D converter input Quadrature: QDZ0 SPI_2: SPI_CLK (master and slave) Auxiliary Clock Output: ACLK0 Battery detect pin in default FW External T/R switch control: ~tx_pd

Note

7. During a power-on reset, all inputs are disabled.

GPIO information

Table 11 WLCSP package GPIO pin descriptions^[7]

Pin number	Pin name	Default direction	After POR	Power domain	Alternate function description
64	P37	Input	Floating	VDDO	<ul style="list-style-type: none"> • GPIO: P37 • A/D converter input • Quadrature: QDZ1 • SPI_2: MISO (slave only) • Auxiliary clock output: ACLK1 • Alternative function: P38, P39
24	P38	Input	Floating	VDDO	<ul style="list-style-type: none"> • GPIO: P38 • A/D converter input • SPI_2: MOSI (master and slave) • IR_TX • XTALO32K (64-BGA only) • Alternate functions: P37, P39
51	P39	Input	Floating	VDDO	<ul style="list-style-type: none"> • GPIO: P39 • SPI_2: SPI_CS (slave only) • SPI_1: MISO (master only) • Infrared control: IR_RX • External PA ramp control: PA_Ramp • XTALI32K (64-BGA only) • 60Hz_main • Alternative function: P37, P38

Note

7. During a power-on reset, all inputs are disabled.

4 Specifications

4.1 Electrical characteristics

Table 12 shows the maximum electrical rating for voltages referenced to VDD pin.

Table 12 Maximum electrical rating

Rating	Symbol	Value	Unit
DC supply voltage for RF domain	–	1.4	V
DC supply voltage for core domain	–	1.4	V
DC supply voltage for VDDM domain (UART/I ² C)	–	3.8	V
DC supply voltage for VDDO domain	–	3.8	V
DC supply voltage for VR3V	–	3.8	V
DC supply voltage for VDDFE	–	1.4	V
Voltage on input or output pin	–	V _{SS} – 0.3 to V _{DD} + 0.3	V
Operating ambient temperature range	Topr	–30 to +85	°C
Storage temperature range	Tstg	–40 to +125	°C

Table 13 shows the power supply characteristics for the range T_J = 0°C to 125°C.

Table 13 Power supply

Parameter	Min ^[8]	Typ	Max ^[8]	Unit
DC supply voltage for RF	1.14	1.2	1.26	V
DC supply voltage for Core	1.14	1.2	1.26	V
DC supply voltage for VDDM (UART/I ² C)	1.62	–	3.63	V
DC supply voltage for VDDO	1.62	–	3.63	V
DC supply voltage for LDOIN	1.425	–	3.63	V
DC supply voltage for VDDFE	1.14	1.2 ^[9]	1.26	V

Notes

8. Overall performance degrades beyond minimum and maximum supply voltages.
9. 1.2 V for Class 2 output with internal VREG.

Table 14 shows the digital level characteristics for (V_{SS} = 0 V).

Table 14 LDO regulator electrical specifications

Parameter	Conditions	Min	Typ	Max	Unit
Input voltage range	–	1.425	–	3.63	V
Default output voltage	–	–	1.2	–	V
Output voltage	Range	0.8	–	1.4	V
	Step size	–	40 or 80	–	mV
	Accuracy at any step	–5	–	+5	%
Load current	–	–	–	30	mA
Line regulation	V _{in} from 1.425 to 3.63 V, I _{load} = 30 mA	–0.2	–	0.2	%V _O /V
Load regulation	I _{load} from 1 μA to 30 mA, V _{in} = 3.3 V, Bonding R = 0.3 Ω	–	0.1	0.2	%V _O /mA
Quiescent current	No load @V _{in} = 3.3 V *Current limit enabled	–	6	–	μA
Power-down current	V _{in} = 3.3V, worst@70°C	–	5	200	nA

Specifications

Table 15 shows the specifications for the ADC characteristics.

Table 15 ADC Specifications

Parameter	Symbol	Conditions	Min	Typ	Max	Unit
Number of Input channels	–	–	–	9	–	–
Channel switching rate	f_{ch}	–	–	–	133.33	kch/s
Input signal range	V_{inp}	–	0	–	3.63	V
Reference settling time	–	Changing refsel	7.5	–	–	μ s
Input resistance	R_{inp}	Effective, single ended	–	500	–	k Ω
Input capacitance	C_{inp}	–	–	–	5	pF
Conversion rate	f_C	–	5.859	–	187	kHz
Conversion time	T_C	–	5.35	–	170.7	μ s
Resolution	R	–	–	16	–	bits
Effective number of bits	–	In specified performance range	–	See Table 2	–	–
Absolute voltage measurement error	–	Using on-chip ADC firmware driver	–	± 2	–	%
Current	I	$I_{avdd1p2} + I_{avdd3p3}$	–	–	1	mA
Power	P	–	–	1.5	–	mW
Leakage current	$I_{leakage}$	T = 25°C	–	–	100	nA
Power-up time	$T_{powerup}$	–	–	–	200	μ s
Integral nonlinearity ^[10]	INL	In guaranteed performance range	–1	–	1	LSB ^[10]
Differential nonlinearity ^[10]	DNL	In guaranteed performance range	–1	–	1	LSB ^[10]

Note

10.LSBs are expressed at the 10-bit level.

Table 16 shows the specifications for the digital voltage levels.

Table 16 Digital levels^[11]

Characteristics	Symbol	Min	Typ	Max	Unit
Input low voltage	V_{IL}	–	–	0.4	V
Input high voltage	V_{IH}	$0.75 \times V_{DDO}$	–	–	V
Input low voltage (VDDO = 1.62 V)	V_{IL}	–	–	0.4	V
Input high voltage (VDDO = 1.62 V)	V_{IH}	1.2	–	–	V
Output low voltage ^[12]	V_{OL}	–	–	0.4	V
Output high voltage ^[12]	V_{OH}	$V_{DDO} - 0.4$	–	–	V
Input capacitance (VDDMEM domain)	C_{IN}	–	0.12	–	pF

Notes

11.This table is also applicable to VDDMEM domain.

12.At the specified drive current for the pad.

Specifications

Table 17 shows the specifications for current consumption.

Table 17 Current consumption ^[13]

Operational Mode	Conditions	Typ	Max	Unit
Receive	Receiver and baseband are both operating, 100% on	9.8	10.0	mA
Transmit	Transmitter and baseband are both operating, 100% on	9.1	9.3	mA
Sleep	Internal LPO is in use	12.0	13.0	μA
	–	0.65	–	

Note

13. Currents measured between power terminals (Vdd) using 90% efficient DC-DC converter at 3 V.

4.2 RF specifications

Table 18 Receiver RF specifications

Parameter	Mode and conditions	Min	Typ	Max	Unit
Receiver section ^[14]					
Frequency range	–	2402	–	2480	MHz
RX sensitivity (standard)	0.1% BER, 1 Mbps, dirty transmitter OFF	–	–93	–	dBm
RX sensitivity (low current)		–	–90	–	dBm
Input IP3	–	–16	–	–	dBm
Maximum input	–	–10	–	–	dBm
Interference performance ^[14, 15]					
C/I cochannel	0.1%BER	–	–	21	dB
C/I 1 MHz adjacent channel	0.1%BER	–	–	15	dB
C/I 2 MHz adjacent channel	0.1%BER	–	–	–17	dB
C/I ≥ 3 MHz adjacent channel	0.1%BER	–	–	–27	dB
C/I image channel	0.1%BER	–	–	–9.0	dB
C/I 1 MHz adjacent to image channel	0.1%BER	–	–	–15	dB
Out-of-band blocking performance (CW) ^[14, 15]					
30 MHz to 2000 MHz	0.1%BER ^[16]	–	–30.0	–	dBm
2003 MHz to 2399 MHz	0.1%BER ^[17]	–	–35	–	dBm
2484 MHz to 2997 MHz	0.1%BER ^[17]	–	–35	–	dBm
3000 MHz to 12.75 GHz	0.1%BER ^[18]	–	–30.0	–	dBm
Spurious emissions					
30 MHz to 1 GHz	–	–	–	–57.0	dBm
1 GHz to 12.75 GHz	–	–	–	–55.0	dBm

Notes

14. 30.8% PER.

15. Desired signal is 3 dB above the reference sensitivity level (defined as –70 dBm).

16. Measurement resolution is 10 MHz.

17. Measurement resolution is 3 MHz.

18. Measurement resolution is 25 MHz.

Table 19 Transmitter RF specifications

Parameter	Min	Typ	Max	Unit
Transmitter section				
Frequency range	2402	–	2480	MHz
Output power adjustment range	–20	–	4	dBm
Default output power	–	4.0	–	dBm
Output power variation	–	2.0	–	dB
Adjacent channel power				
$ M - N = 2$	–	–	–20	dBm
$ M - N \geq 3$	–	–	–30	dBm
Out-of-band spurious emission				
30 MHz to 1 GHz	–	–	–36.0	dBm
1 GHz to 12.75 GHz	–	–	–30.0	dBm
1.8 GHz to 1.9 GHz	–	–	–47.0	dBm
5.15 GHz to 5.3 GHz	–	–	–47.0	dBm
LO performance				
Initial carrier frequency tolerance	–	–	±150	kHz
Frequency Drift				
Frequency drift	–	–	±50	kHz
Drift rate	–	–	20	kHz/50 μs
Frequency deviation				
Average deviation in payload (sequence used is 00001111)	225	–	275	kHz
Maximum deviation in payload (sequence used is 10101010)	185	–	–	kHz
Channel spacing	–	2	–	MHz

4.3 Timing and AC characteristics

In this section, use the numbers listed in the **Reference** column of each table to interpret the following timing diagrams.

4.3.1 UART timing

Table 20 UART timing specifications

Reference	Characteristics	Min	Max	Unit
1	Delay time, UART_CTS_N LOW to UART_TXD valid	–	24	Baud out cycles
2	Setup time, UART_CTS_N high before midpoint of stop bit	–	10	ns
3	Delay time, midpoint of stop bit to UART_RTS_N high	–	2	Baud out cycles

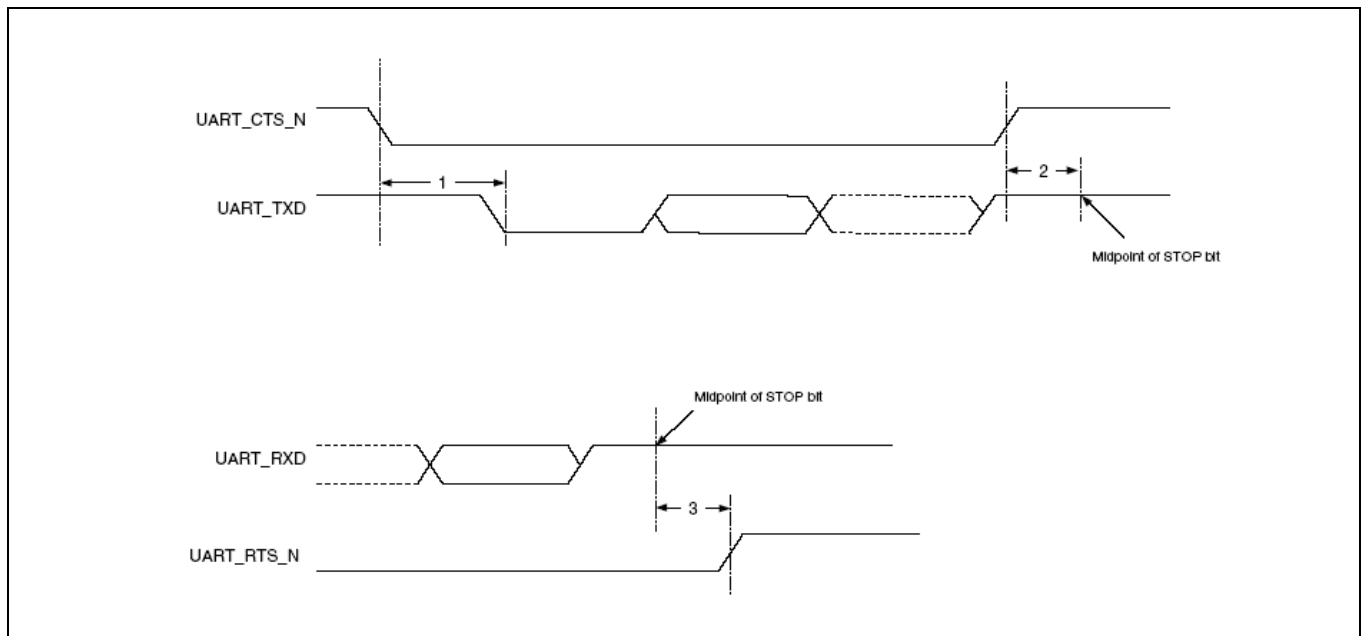

Figure 11 UART timing

4.3.2 SPI timing

The SPI interface supports clock speeds up to 12 MHz with $VDDIO \geq 2.2$ V. The supported clock speed is 6 MHz when 2.2 V > $VDDIO \geq 1.62$ V.

Figure 12 and **Figure 13** show the timing requirements when operating in SPI Mode 0 and 2, and SPI Mode 1 and 3, respectively.

Table 21 SPI interface timing specifications

Reference	Characteristics	Min	Typ	Max
1	Time from CSN asserted to first clock edge	1 SCK	100	∞
2	Master setup time	–	$\frac{1}{2}$ SCK	–
3	Master hold time	$\frac{1}{2}$ SCK	–	–
4	Slave setup time	–	$\frac{1}{2}$ SCK	–
5	Slave hold time	$\frac{1}{2}$ SCK	–	–
6	Time from last clock edge to CSN deasserted	1 SCK	10 SCK	100

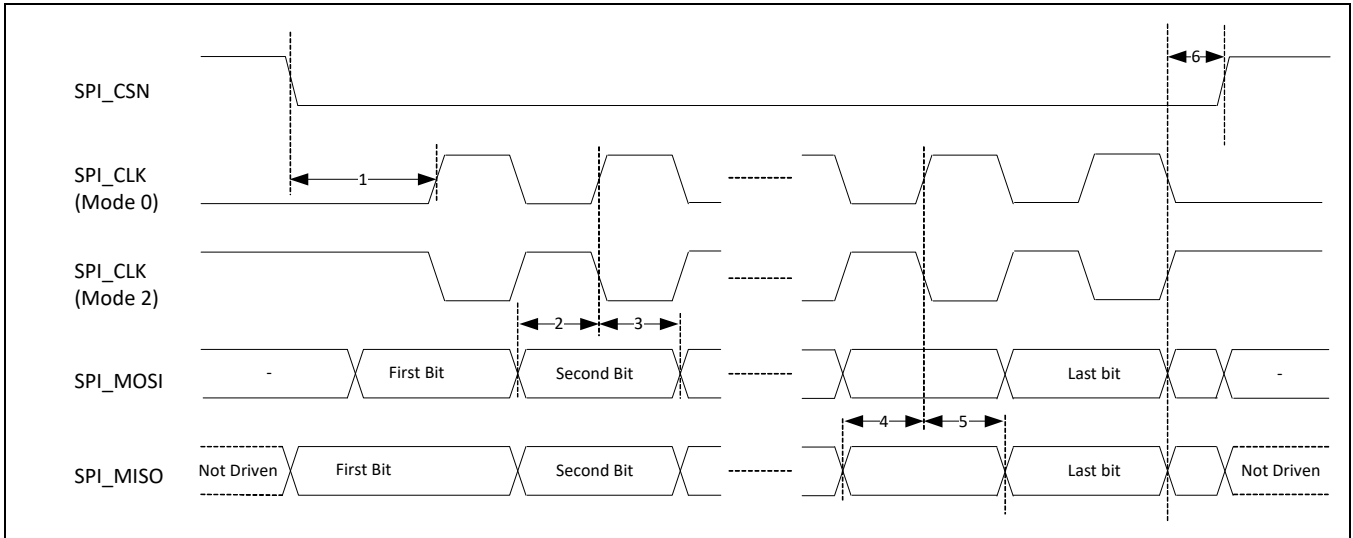

Figure 12 SPI timing – Mode 0 and 2

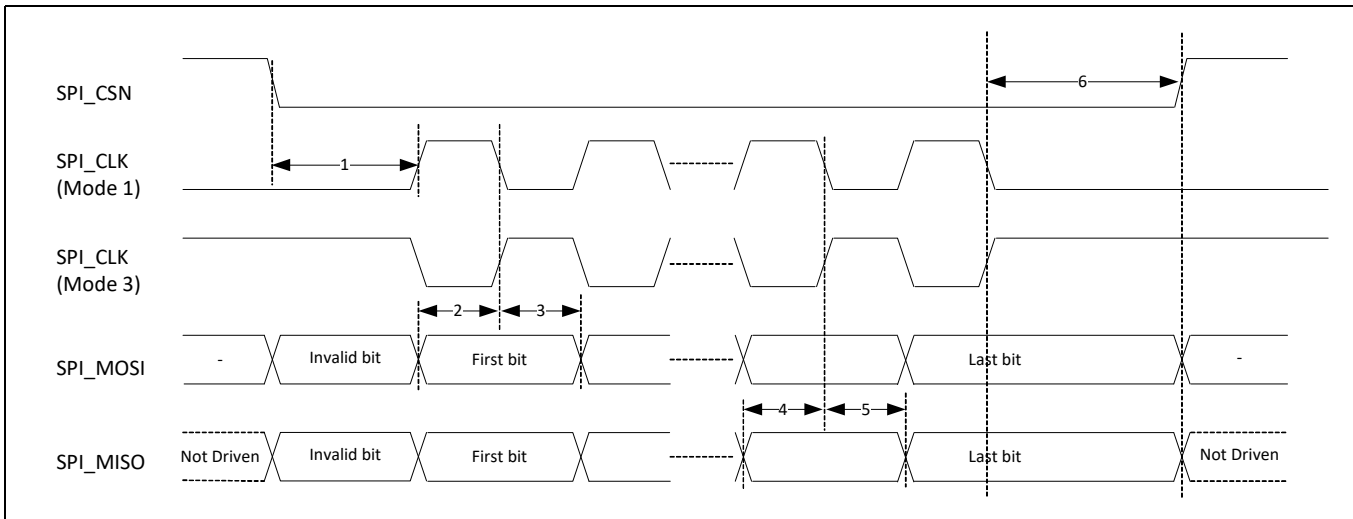

Figure 13 SPI timing – Mode 1 and 3

4.3.3 BSC interface timing

Table 22 BSC interface timing specifications

Reference	Characteristics	Min	Max	Unit
1	Clock frequency	-	100	kHz
			400	
			800	
			1000	
2	START condition setup time	650	-	ns
3	START condition hold time	280	-	ns
4	Clock low time	650	-	ns
5	Clock high time	280	-	ns
6	Data input hold time ^[19]	0	-	ns
7	Data input setup time	100	-	ns
8	STOP condition setup time	280	-	ns
9	Output valid from clock	-	400	ns
10	Bus free time ^[20]	650	-	ns

Notes

19.As a transmitter, 300 ns of delay is provided to bridge the undefined region of the falling edge of SCL to avoid unintended generation of START or STOP conditions.

20.Time that the CBUS must be free before a new transaction can start.

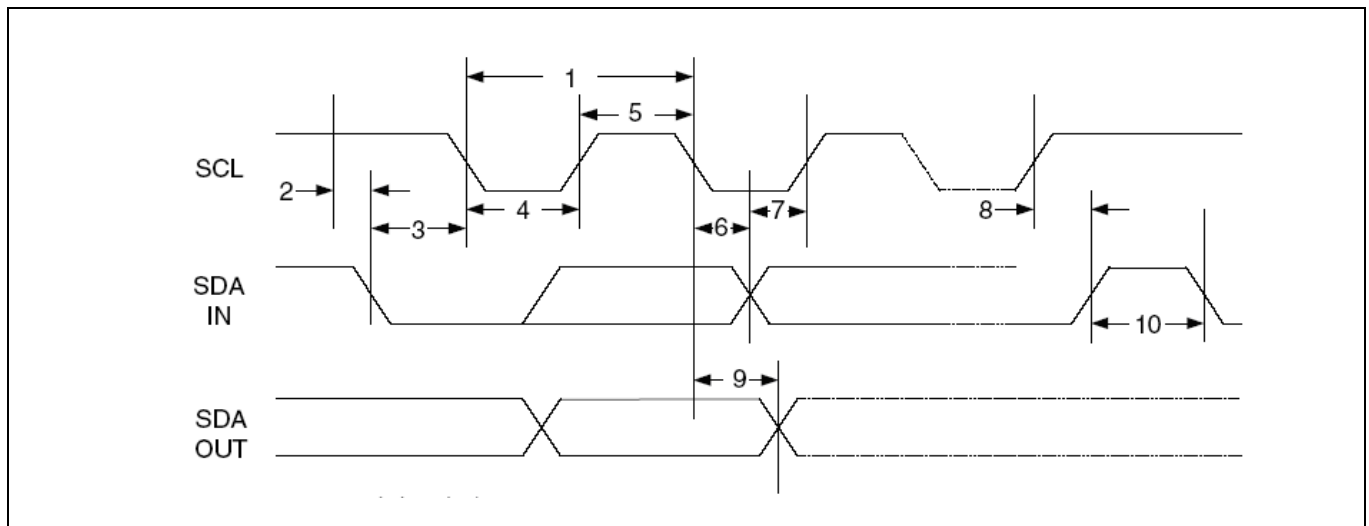

Figure 14 BSC interface timing diagram

4.4 Electrostatic discharge (ESD) test models

The ESD can have serious detrimental effects on all semiconductor ICs and the system that contains them. Standards are developed to enhance the quality and reliability of ICs by ensuring all devices employed have undergone proper ESD design and testing, thereby minimizing the detrimental effects of ESD. Three major test methods are widely used in the industry today to describe uniform methods for assessing ESD immunity at Component level, Human Body Model (HBM), Machine Model (MM), and Charged Device Model (CDM). The following standards were used to test this device:

4.4.1 Human-Body Model (HBM) – ANSI/ESDA/JEDEC JS-001-2012

The HBM has been developed to simulate the action of a human body discharging an accumulated static charge through a device to ground, and employs a series RC network consisting of a 100 pF capacitor and a 1500Ω (Ohm) resistor. Both positive and negative polarities are used for this test. Although, a 100 ms delay is allowable per specification, the minimum delay used for testing was set to 300 ms between each pulse.

4.4.2 Machine Model (MM) – JEDEC JESD22-A115C

The MM has been developed to simulate the rapid discharge from a charged conductive object, such as a metallic tool or fixture. The most common application would be rapid discharge from charged board assembly or the charged cables of automated testers. This model consists of a 200 pF capacitor discharged directly into a component with no series resistor (0 Ω). One positive and one negative polarity pulses are applied. The minimum delay between pulses is 500 ms.

4.4.3 Charged-Device Model (CDM) - JEDEC JESD22-C101E

The CDM simulates charging/discharging events that occur in production equipment and processes. The potential for a CDM ESD events occurs when there is metal-to-metal contact in manufacturing. The CDM addresses the possibility that a charge may reside on the lead frame or package (for example, from shipping) and discharge through a pin that subsequently is grounded, causing damage to sensitive devices in the path. Discharge current is limited only by the parasitic impedance and capacitance of the device. The CDM testing consists of charging package to a specified voltage, then discharging the voltage through relevant package leads. One positive and one negative polarity pulse is applied. The minimum delay between pulses is 200 ms.

4.4.4 Results summary

ESD test voltage level results:

- HBM +/- 2KV PASS
- CDM +/- 500V PASS
- MM +/- 150V PASS

5 Mechanical information

5.1 QFN

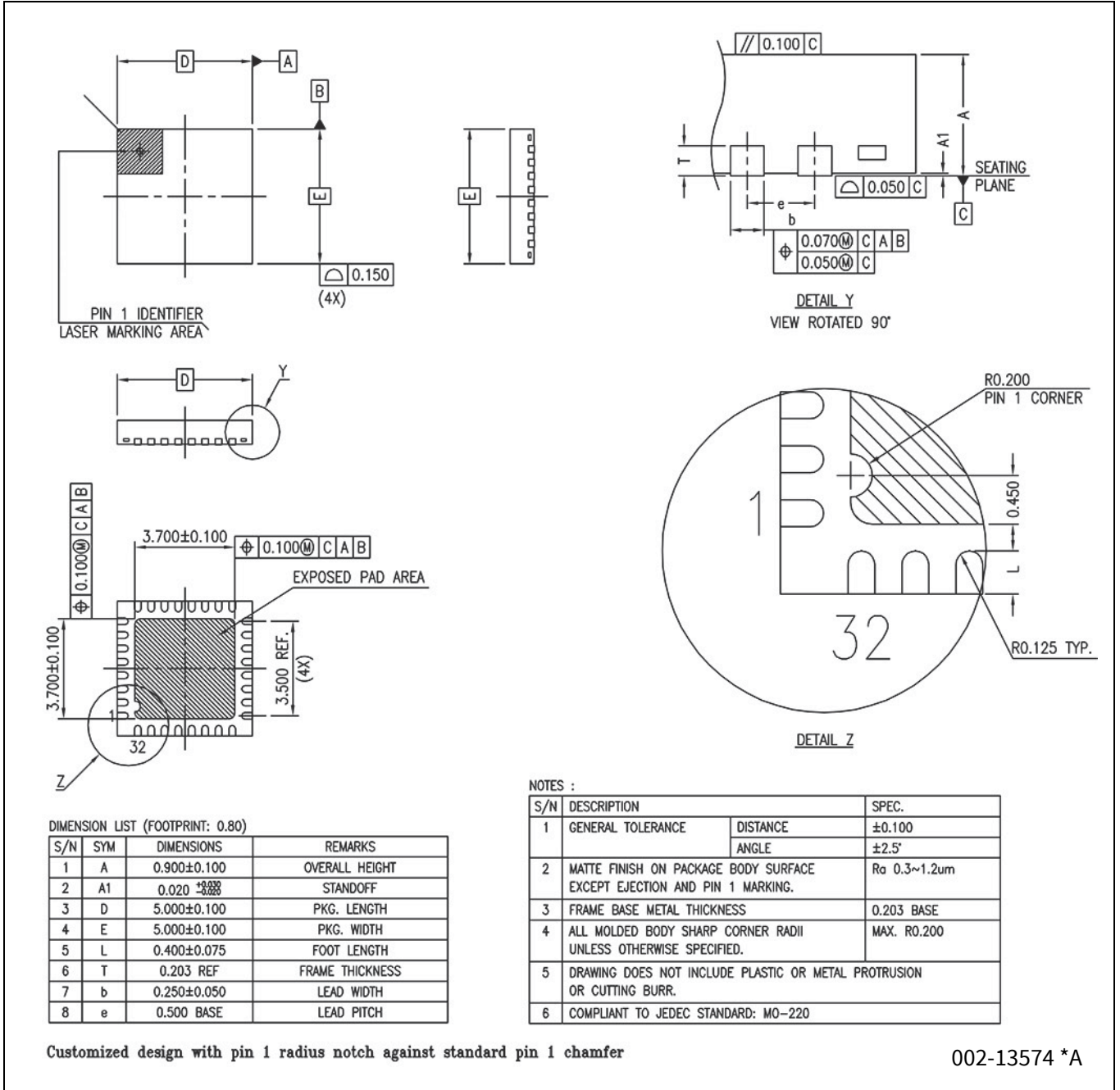

Figure 15 32-pin QFN (5.0 × 5.0 × 1.0 mm) LT32D (PG-VQFN-32)

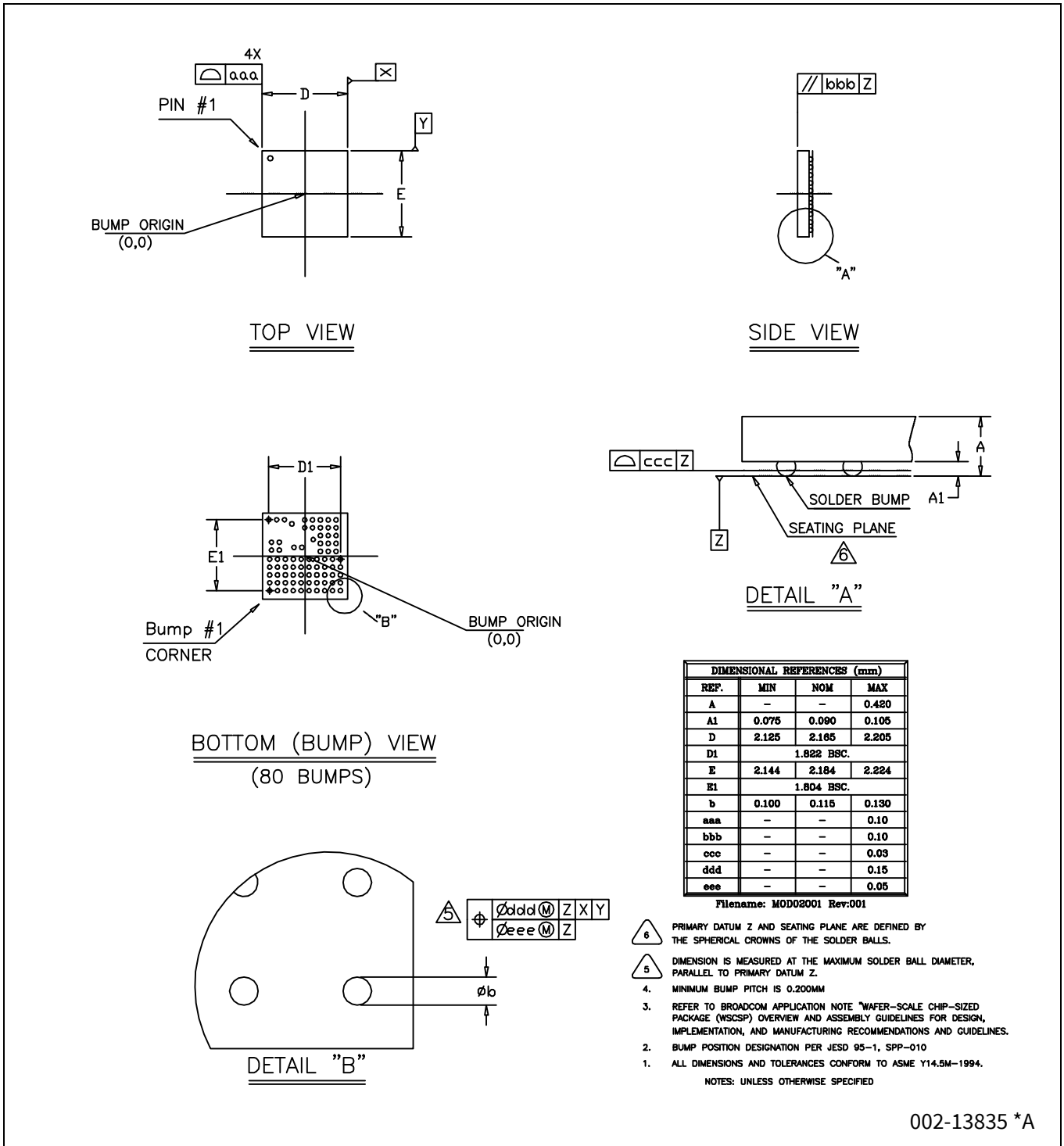

Figure 16 80-ball WLCSP (2.165 × 2.184 × 0.42 mm) FN80A (SG-XFWLB-80)

5.1.1 Tape reel and packaging specifications

Table 23 CYW20736 5 × 5 × 1 mm QFN, 32-pin tape reel specifications

Parameter	Value
Quantity per reel	2500 pieces
Reel diameter	13 inches
Hub diameter	7 inches
Tape width	12 mm
Tape pitch	8 mm

The top left corner of the CYW20736 package is situated near the sprocket holes, as shown in **Figure 18**.

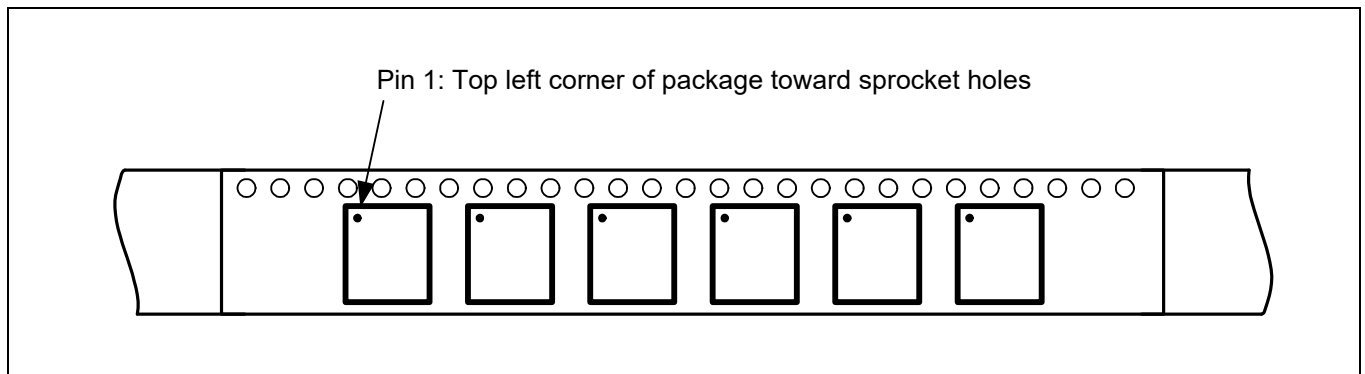

Figure 18 Pin 1 orientation

5.2 WLCSP

Table 24 provides WLCSP package information.

Table 24 WLCSP package information

Parameter	Value
Wafer process	65 nm
Chip size without seal ring and scribe line	2104 μm × 2085 μm
Chip size with seal ring and scribe line	2224 μm × 2205 μm (S+S 120 μm)
Module die size	2184 μm × 2165 μm
UBM size	88 μm
Bump height	90 μm
Bump diameter	115 μm
Bump pitch	200 μm (min)

Ordering information

6 Ordering information

Table 25 Ordering information

Product	Package	Ambient operating temperature
CYW20736A1KML2G	32-pin QFN	-30°C to +85°C
CYW20736A1KWBGT	80-pin WLCSP	-30°C to +85°C

7 Acronyms and abbreviations

The following list of acronyms and abbreviations may appear in this document.

Term	Description
ADC	analog-to-digital converter
AFH	adaptive frequency hopping
AHB	advanced high-performance bus
APB	advanced peripheral bus
APU	audio processing unit
ARM7TDMI-S	Acorn RISC Machine 7 Thumb instruction, Debugger, Multiplier, Ice, Synthesizable
BSC	Broadcom Serial Control
BTC	Bluetooth® controller
COEX	coexistence
DFU	device firmware update
DMA	direct memory access
EBI	external bus interface
HCI	Host Control Interface
HV	high voltage
IDC	initial digital calibration
IF	intermediate frequency
IRQ	interrupt request
JTAG	Joint Test Action Group
LCU	link control unit
LDO	low drop-out
LHL	lean high land
LPO	low power oscillator
LV	LogicVision
MIA	multiple interface agent
PCM	pulse code modulation
PLL	phase locked loop
PMU	power management unit
POR	power-on reset
PWM	pulse width modulation
QD	quadrature decoder
RAM	random access memory
RF	radio frequency
ROM	read-only memory
RX/TX	receive, transmit
SPI	serial peripheral interface
SW	software
UART	universal asynchronous receiver/transmitter
UPI	μ-processor interface
WD	watchdog

Revision history

Document revision	Date	Description of changes
**	2014-01-03	20736-DS100-R: Initial release.
*A	2014-07-11	20736-DS101-R: Updated: Ordering information on page 46.
*B	2014-08-15	20736-DS102-R: Updated: “List of Tables”.
*C	2015-04-10	20736-DS103-R: Updated: Table 5 on page 12. Pin information on page 16 with new WLCSP content. By moving GPIO Information to the following new GPIO information on page 25.
*D	2015-04-21	20736-DS104-R: Updated: Table 18 on page 36
*E	2015-04-27	20736-DS105-R: Updated: Features on page 1: added WLCSP package information. Table 5 on page 12 and Table 5 on page 12: corrected an error in the unit of measure for drive level and XTAL drive level, respectively. Ordering information on page 46. Added: Figure 16 on page 43. Figure 17 on page 44 (Top View, Bumps Facing Down).
*F	2016-02-16	20736-DS106-R: Added: Electrostatic discharge (ESD) test models on page 41.
*G	2016-09-30	Updated to Cypress template.
*H	2017-04-24	Updated Cypress logo. Updated Copyright.
*I	2017-06-30	Updated the Title. Removed (aka Bluetooth Smart) from Page 1. Replaced Alliance with Wireless Power to AirFuel in Application on Page 1. Removed Wireless Charging Section from the datasheet.
*J	2024-09-24	Migrated to Infineon template. Updated Features on page 1. and Added the Spec# and IFX package code for Figure 15 and Figure 16.

Trademarks

All referenced product or service names and trademarks are the property of their respective owners.

Edition 2024-09-24

Published by

**Infineon Technologies AG
81726 Munich, Germany**

**© 2024 Infineon Technologies AG.
All Rights Reserved.**

Do you have a question about this document?

Email:

erratum@infineon.com

Document reference

002-14883 Rev. *J

IMPORTANT NOTICE

The information given in this document shall in no event be regarded as a guarantee of conditions or characteristics ("Beschaffenheitsgarantie").

With respect to any examples, hints or any typical values stated herein and/or any information regarding the application of the product, Infineon Technologies hereby disclaims any and all warranties and liabilities of any kind, including without limitation warranties of non-infringement of intellectual property rights of any third party.

In addition, any information given in this document is subject to customer's compliance with its obligations stated in this document and any applicable legal requirements, norms and standards concerning customer's products and any use of the product of Infineon Technologies in customer's applications.

The data contained in this document is exclusively intended for technically trained staff. It is the responsibility of customer's technical departments to evaluate the suitability of the product for the intended application and the completeness of the product information given in this document with respect to such application.

WARNINGS

Due to technical requirements products may contain dangerous substances. For information on the types in question please contact your nearest Infineon Technologies office.

Except as otherwise explicitly approved by Infineon Technologies in a written document signed by authorized representatives of Infineon Technologies, Infineon Technologies' products may not be used in any applications where a failure of the product or any consequences of the use thereof can reasonably be expected to result in personal injury.